

# **C2000 Digital Control Library**

**Version 3.4**

## **User's Guide**



February 2020



# Read This First

---

---

---

### ***About This Manual***

This User's Guide covers version 3.4 of the C2000 Digital Control Library (DCL). It contains technical descriptions of the library functions and how to use them. The DCL User's Guide does not cover control applications, control theory, or technical details of C2000 devices; however some information on these topics may be found in the references listed in chapter 6.

The User's Guide is divided into six chapters. Chapter 1 presents a general introduction to the library and provides background information. Chapter 2 describes the library contents and structure, how to add library functions to a user's program, and how to migrate existing source code. Chapter 3 describes the controllers and supporting functions, and provides information on their use. Chapter 4 describes the utilities supplied with the library, including data loggers, a transient capture module, and simulation models. Chapter 5 describes a set of supporting software examples which illustrate the use of the library. A list of relevant technical references and training can be found in Chapter 6.

### ***How to Use This Manual***

New users are advised to begin by reading the library overview in chapter 1. Chapter 2 provides a useful step-by-step guide of how to integrate the library into an existing C program as well as how to migrate from earlier versions, and should be read carefully by all users. Once the user has decided on the type of controller to implement, performance and other important information in the relevant sub-section of chapter 3 should be read carefully. If data array management or performance measurement is required, the utilities described in chapter 4 may be of interest. The library includes a number of software examples which illustrate the use of most of the controllers. These are described in chapter 5 and should serve as a good starting point for new users. Finally, for further reading and other resources, users are directed to the list of technical references and training materials in chapter 6.

### ***Related Documentation from Texas Instruments***

Technical documentation and development tools for the C2000 device can be found online on the Texas Instruments website at [www.ti.com/c2000](http://www.ti.com/c2000).

### ***If You Need Assistance***

Technical support for C2000 products is available online via the TI "E2E" Community: [e2e.ti.com/support/microcontrollers/c2000](http://e2e.ti.com/support/microcontrollers/c2000)

# Contents

---

---

<b>Read This First</b> .....	<b>iii</b>
About This Manual.....	iii
How to Use This Manual.....	iii
Related Documentation from Texas Instruments.....	iii
If You Need Assistance .....	iii
<b>Contents</b> .....	<b>iv</b>
<b>Figures</b> .....	<b>xii</b>
<b>Tables</b> .....	<b>xiii</b>
<b>Introduction</b> .....	<b>1</b>
1.1 Supported Devices.....	1
1.2 Overview of the Library .....	2
1.3 New In This Version .....	3
1.3.1 New Features .....	3
1.3.2 Bug Fixes.....	4
1.3.3 Function Naming .....	4
1.3.4 Structure Naming .....	5
1.3.5 Support Sub-structures .....	5
1.3.6 Calling Convention .....	5
1.3.7 Data Types .....	5
1.3.8 The ZPK3 Structure.....	5
1.3.9 Compensator Stability Tests .....	6
1.3.10 Deprecated Modules .....	6
1.4 CPU Compatibility.....	6
1.5 Benchmarks .....	7
1.5.1 Controller Benchmarks.....	7
1.5.2 Controller Support Function Benchmarks .....	9
1.5.3 Fast Update Function Benchmarks.....	11
1.5.4 FPU64 Function Benchmarks .....	13
<b>Using the Digital Control Library</b> .....	<b>14</b>
2.1 What the Library Contains .....	14
2.1.1 Header Files .....	14
2.1.2 Source Files.....	15
2.1.3 Examples.....	16
2.2 Header File Dependency .....	16
2.3 How to Add the DCL to User Code .....	18
2.3.1 Steps to Add the DCL to Existing C Code.....	18
2.3.2 Calling the Library Functions from Assembly.....	21
2.4 Updating Controller Parameters .....	21
2.5 Error Handling.....	23
2.6 How to Modify the Library Code.....	25
<b>Controllers</b> .....	<b>26</b>
3.1 Linear PID Controllers.....	27
3.1.1 Description.....	27
3.1.2 Implementation.....	29
3.1.3 Functions .....	32
<i>DCL_runPID_C1</i> .....	32

<i>DCL_runPID_C2</i> .....	32
<i>DCL_runPID_C3</i> .....	33
<i>DCL_runPID_C4</i> .....	33
<i>DCL_runPID_L1</i> .....	34
<i>DCL_runPID_L2</i> .....	34
<i>DCL_resetPID</i> .....	34
<i>DCL_updatePID</i> .....	35
<i>DCL_fupdatePID</i> .....	35
<i>DCL_setPIDfilterBW</i> .....	35
<i>DCL_setActivePIDfilterBW</i> .....	36
<i>DCL_getPIDfilterBW</i> .....	36
<i>DCL_loadSeriesPIDasZPK</i> .....	36
<i>DCL_loadParallelPIDasZPK</i> .....	37
3.2 Linear PI Controllers.....	37
3.2.1 Description.....	37
3.2.2 Implementation.....	38
3.2.3 Functions.....	40
<i>DCL_runPI_C1</i> .....	40
<i>DCL_runPI_C2</i> .....	40
<i>DCL_runPI_C3</i> .....	40
<i>DCL_runPI_C4</i> .....	41
<i>DCL_runPI_C5</i> .....	41
<i>DCL_runPI_C6</i> .....	42
<i>DCL_runPI_C7</i> .....	42
<i>DCL_runPI_L1</i> .....	42
<i>DCL_runPI_L2</i> .....	43
<i>DCL_runPI_L3</i> .....	43
<i>DCL_runPI_L4</i> .....	43
<i>DCL_runPI_L5</i> .....	44
<i>DCL_resetPI</i> .....	44
<i>DCL_updatePI</i> .....	44
<i>DCL_fupdatePI</i> .....	45
<i>DCL_loadSeriesPIasZPK</i> .....	45
<i>DCL_loadParallelPIasZPK</i> .....	45
3.3 Non-linear PID Controller.....	46
3.3.1 Description.....	46
3.3.2 Implementation.....	50
3.3.3 Functions.....	51
<i>DCL_runNLPID_C1</i> .....	51
<i>DCL_runNLPID_C2</i> .....	51
<i>DCL_runNLPID_C3</i> .....	52
<i>DCL_setActiveNLPIDGamma</i> .....	52
<i>DCL_setNLPIDGamma</i> .....	52
<i>DCL_resetNLPID</i> .....	53
<i>DCL_updateNLPID</i> .....	53
<i>DCL_setActiveNLPIDfilterBW</i> .....	53
<i>DCL_setNLPIDfilterBW</i> .....	54
<i>DCL_getNLPIDfilterBW</i> .....	54
<i>DCL_getNLPIDgamma</i> .....	54
<i>DCL_getNLPIDdelta</i> .....	55
3.4 Non-linear PI Controllers.....	55

3.4.1	Description.....	55
3.4.2	Implementation.....	55
3.4.3	Functions.....	56
	<i>DCL_runNLPI_C1</i> .....	56
	<i>DCL_resetNLPI</i> .....	56
	<i>DCL_updateNLPI</i> .....	56
3.5	Double Integrator PI Controller.....	57
3.5.1	Description.....	57
3.5.2	Implementation.....	57
3.5.3	Functions.....	57
	<i>DCL_runPI2_C1</i> .....	57
	<i>DCL_resetPI2</i> .....	58
	<i>DCL_updatePI2</i> .....	58
	<i>DCL_fupdatePI2</i> .....	59
3.6	Direct Form 1 (First Order) Compensators.....	59
3.6.1	Description.....	59
3.6.2	Implementation.....	60
3.6.3	Functions.....	60
	<i>DCL_runDF11_C1</i> .....	60
	<i>DCL_runDF11_C2</i> .....	60
	<i>DCL_runDF11_L1</i> .....	61
	<i>DCL_resetDF11</i> .....	61
	<i>DCL_updateDF11</i> .....	61
	<i>DCL_fupdateDF11</i> .....	62
	<i>DCL_isStableDF11</i> .....	62
	<i>DCL_loadDF11asZPK</i> .....	62
	<i>DCL_loadDF11asPI</i> .....	63
3.7	Direct Form 1 (Third Order) Compensators.....	63
3.7.1	Description.....	63
3.7.2	Implementation.....	65
3.7.3	Functions.....	67
	<i>DCL_runDF13_C1</i> .....	67
	<i>DCL_runDF13_C2</i> .....	67
	<i>DCL_runDF13_C3</i> .....	67
	<i>DCL_runDF13_C4</i> .....	68
	<i>DCL_runDF13_C5</i> .....	68
	<i>DCL_runDF13_C6</i> .....	68
	<i>DCL_runDF13_L1</i> .....	69
	<i>DCL_runDF13_L2</i> .....	69
	<i>DCL_runDF13_L3</i> .....	69
	<i>DCL_runDF13_L4</i> .....	70
	<i>DCL_runDF13_L5</i> .....	70
	<i>DCL_runDF13_L6</i> .....	70
	<i>DCL_resetDF13</i> .....	71
	<i>DCL_updateDF13</i> .....	71
	<i>DCL_fupdateDF13</i> .....	72
	<i>DCL_isStableDF13</i> .....	72
	<i>DCL_loadDF13asZPK</i> .....	72
3.8	Direct Form 2 (Second Order) Compensators.....	73
3.8.1	Description.....	73
3.8.2	Implementation.....	74
3.8.3	Functions.....	75

---

<i>DCL_runDF22_C1</i> .....	75
<i>DCL_runDF22_C2</i> .....	75
<i>DCL_runDF22_C3</i> .....	75
<i>DCL_runDF22_C4</i> .....	76
<i>DCL_runDF22_C5</i> .....	76
<i>DCL_runDF22_C6</i> .....	76
<i>DCL_runDF22_L1</i> .....	77
<i>DCL_runDF22_L2</i> .....	77
<i>DCL_runDF22_L3</i> .....	77
<i>DCL_runDF22_L4</i> .....	78
<i>DCL_resetDF22</i> .....	78
<i>DCL_updateDF22</i> .....	78
<i>DCL_fupdateDF22</i> .....	79
<i>DCL_isStableDF22</i> .....	79
<i>DCL_loadDF22asZPK</i> .....	79
<i>DCL_loadDF22asZwn</i> .....	80
<i>DCL_loadDF22asParallelPID</i> .....	80
<i>DCL_loadDF22asSeriesPID</i> .....	81
3.9 Direct Form 2 (Third Order) Compensators .....	81
3.9.1 Description .....	81
3.9.2 Implementation .....	83
3.9.3 Functions .....	83
<i>DCL_runDF23_C1</i> .....	83
<i>DCL_runDF23_C2</i> .....	84
<i>DCL_runDF23_C3</i> .....	84
<i>DCL_runDF23_C4</i> .....	84
<i>DCL_runDF23_C5</i> .....	85
<i>DCL_runDF23_C6</i> .....	85
<i>DCL_runDF23_L1</i> .....	85
<i>DCL_runDF23_L2</i> .....	86
<i>DCL_runDF23_L3</i> .....	86
<i>DCL_resetDF23</i> .....	86
<i>DCL_updateDF23</i> .....	87
<i>DCL_fupdateDF23</i> .....	87
<i>DCL_isStableDF23</i> .....	87
<i>DCL_loadDF23asZPK</i> .....	88
3.10 Fixed-Point PID Controllers .....	88
3.10.1 Description .....	88
3.10.2 Implementation .....	88
3.10.3 Functions .....	90
<i>DCL_runPID_A1</i> .....	90
<i>DCL_resetPID32</i> .....	91
<i>DCL_updatePID32</i> .....	91
<i>DCL_fupdatePID32</i> .....	91
3.11 Fixed-Point PI Controllers .....	92
3.11.1 Description .....	92
3.11.2 Implementation .....	92
3.11.3 Functions .....	93
<i>DCL_runPI_A1</i> .....	93
<i>DCL_resetPI32</i> .....	93
<i>DCL_updatePI32</i> .....	94
<i>DCL_fupdatePI32</i> .....	94

3.12 Gain Scheduler Module .....	94
3.12.1 Description.....	94
3.12.2 Implementation.....	95
3.12.3 Functions.....	96
<i>DCL_runGSM_C1</i> .....	96
<i>DCL_resetGSM</i> .....	96
<i>DCL_updateGSM</i> .....	96
<i>DCL_fupdateGSM</i> .....	97
<i>DCL_loadGSMoffsets</i> .....	97
<i>DCL_loadGSMgains</i> .....	97
3.13 Non-linear Control Law .....	98
3.13.1 Description.....	98
3.13.2 Implementation.....	98
3.13.3 Functions.....	98
<i>DCL_runNLF_C1</i> .....	98
3.14 Double Precision PID Controllers .....	98
3.14.1 Description.....	98
3.14.2 Implementation.....	99
3.14.3 Functions.....	99
<i>DCL_runPIDF64_S1</i> .....	99
<i>DCL_resetPIDF64</i> .....	99
<i>DCL_updatePIDF64</i> .....	99
<i>DCL_setPIDF64filterBW</i> .....	100
<i>DCL_setActivePIDF64filterBW</i> .....	100
<i>DCL_getPIDF64filterBW</i> .....	100
3.15 Double Precision DF22 Compensators.....	101
3.15.1 Description.....	101
3.15.2 Implementation.....	101
3.15.3 Functions.....	101
<i>DCL_runDF22F64_S1</i> .....	101
<i>DCL_runDF22F64_S2</i> .....	101
<i>DCL_runDF22F64_S3</i> .....	102
<i>DCL_resetDF22F64</i> .....	102
<i>DCL_updateDF22F64</i> .....	102
<b>Utilities.....</b>	<b>104</b>
4.1 Control Clamps .....	104
4.1.1 Description.....	104
4.1.2 Functions.....	105
<i>DCL_runClamp_C1</i> .....	105
<i>DCL_runClamp_C2</i> .....	105
<i>DCL_runClamp_L1</i> .....	106
<i>DCL_runClamp_S1</i> .....	106
4.2 Floating Point Data Logging Functions .....	107
4.2.1 Description.....	107
4.2.2 Functions.....	108
<i>DCL_deleteLog</i> .....	108
<i>DCL_resetLog</i> .....	108
<i>DCL_initLog</i> .....	109
<i>DCL_writeLog</i> .....	109
<i>DCL_fillLog</i> .....	109
<i>DCL_clearLog</i> .....	110
<i>DCL_readLog</i> .....	110



---

<i>DCL_copyLog</i> .....	110
<i>DCL_freadLog</i> .....	111
<i>DCL_fwriteLog</i> .....	111
4.3 4-channel Floating Point Data Logger .....	111
4.3.1 Description .....	111
4.3.2 Functions .....	112
<i>DCL_initMLOG</i> .....	112
<i>DCL_resetMLOG</i> .....	113
<i>DCL_armMLOG</i> .....	113
<i>DCL_runMLOG</i> .....	114
4.4 Transient Capture Module .....	114
4.4.1 TCM_idle Mode .....	115
4.4.2 TCM_armed Mode .....	115
4.4.3 TCM_capture Mode .....	116
4.4.4 TCM_complete Mode .....	118
4.4.5 Functions .....	118
<i>DCL_initTCM</i> .....	118
<i>DCL_resetTCM</i> .....	119
<i>DCL_armTCM</i> .....	119
<i>DCL_runTCM</i> .....	119
4.5 Performance Measurement .....	120
4.5.1 Description .....	120
4.5.2 Functions .....	121
<i>DCL_runIES_C1</i> .....	121
<i>DCL_runIES_C2</i> .....	121
<i>DCL_runIAE_C1</i> .....	122
<i>DCL_runIAE_C2</i> .....	122
<i>DCL_runITAE_C1</i> .....	122
<i>DCL_runITAE_C2</i> .....	122
4.6 Fixed Point Data Logger Support .....	123
4.6.1 Description .....	123
4.6.2 Functions .....	123
<i>DCL_deleteLog32</i> .....	123
<i>DCL_resetLog32</i> .....	123
<i>DCL_initLog32</i> .....	124
<i>DCL_writeLog32</i> .....	124
<i>DCL_fillLog32</i> .....	124
<i>DCL_clearLog32</i> .....	125
<i>DCL_readLog32</i> .....	125
<i>DCL_copyLog32</i> .....	125
<i>DCL_initMLOG32</i> .....	125
<i>DCL_resetMLOG32</i> .....	126
<i>DCL_armMLOG32</i> .....	126
<i>DCL_runMLOG32</i> .....	127
4.7 Simulation Models .....	127
4.7.1 The DCL Block-set .....	127
4.7.2 Simulation Example .....	128
4.8 Double Precision Data Logging Functions .....	128
4.8.1 Description .....	128
4.8.2 Functions .....	129
<i>DCL_deleteLog64</i> .....	130
<i>DCL_resetLog64</i> .....	130

<i>DCL_initLog64</i> .....	130
<i>DCL_writeLog64</i> .....	130
<i>DCL_fillLog64</i> .....	131
<i>DCL_clearLog64</i> .....	131
<i>DCL_readLog64</i> .....	131
<i>DCL_copyLog64</i> .....	132
<b>Examples</b> .....	<b>133</b>
5.1 Example 1: DF22 Compensator Running on FPU32 .....	134
5.1.1 Example Overview .....	134
5.1.2 Code Description .....	134
5.1.3 Running the Example .....	135
5.2 Example 2: DF23 Compensator Running on CLA .....	136
5.2.1 Example Overview .....	136
5.2.2 Code Description .....	136
5.2.3 Running the Example .....	137
5.3 Example 3: NLPID Controller Running on FPU32 .....	138
5.3.1 Example Overview .....	138
5.3.2 Code Description .....	138
5.3.3 Running the Example .....	139
5.4 Example 4: PI Controller Running on CLA .....	140
5.4.1 Example Overview .....	140
5.4.2 Code Description .....	140
5.4.3 Running the Example .....	140
5.5 Example 5: PID Controller Running on FPU32 .....	141
5.5.1 Example Overview .....	141
5.5.2 Code Description .....	141
5.5.3 Running the Example .....	142
5.6 Example 6: TCM Running on FPU32 .....	142
5.6.1 Example Overview .....	142
5.6.2 Code Description .....	143
5.6.3 Running the Example .....	143
5.7 Example 7: Smith Predictor Running on FPU32 .....	144
5.7.1 Example Overview .....	144
5.7.2 Code Description .....	145
5.7.3 Running the Example .....	145
5.8 Example 8: GSM Running on FPU32 .....	145
5.8.1 Example Overview .....	145
5.8.2 Code Description .....	145
5.8.3 Running the Example .....	146
5.9 Example 9: Multiple Controller System with ERAD Running on FPU32 .....	147
5.9.1 Example Overview .....	147
5.9.2 Code Description .....	149
5.9.3 Running the Example .....	149
5.10 Example 10: PID Running on FPU64 .....	150
5.10.1 Example Overview .....	150
5.10.2 Code Description .....	150
5.10.3 Running the Example .....	151
5.11 Example 11: NLPID Running on FPU32 (TMU1) .....	152
5.11.1 Example Overview .....	152
5.11.2 Code Description .....	152
5.11.3 Running the Example .....	152
<b>Support</b> .....	<b>154</b>
6.1 References .....	154
6.1.1 C2000 Documentation .....	154

6.1.2 Literature .....	154
6.2 Training .....	155
6.3 Support.....	155

# Figures

Figure 1.	DCL function naming .....	4
Figure 2.	DCL Controller Header File Dependency .....	17
Figure 3.	DCL Data Logger Header Dependency .....	17
Figure 4.	CCSv6 Include Options .....	19
Figure 5.	Parallel form PID controller .....	28
Figure 6.	PID control action .....	29
Figure 7.	DCL_PID C1, C2, & L1 architecture .....	31
Figure 8.	DCL_PID C3, C4, & L2 architecture .....	32
Figure 9.	DCL_PI C1, C2, L1, & L3 architecture .....	38
Figure 10.	DCL_PI C3, C4, L2 & L4 architecture .....	38
Figure 11.	DCL_PI C5 architecture .....	39
Figure 12.	DCL_PI C6, C7, & L5 architecture .....	39
Figure 13.	DCL_NLPID C1 input architecture .....	46
Figure 14.	DCL_NLPID C1 output architecture .....	47
Figure 15.	DCL_NLPID C2 & C3 architecture .....	47
Figure 16.	Non-linear control law input-output plot .....	48
Figure 17.	Gain vs error curves for varying alpha .....	49
Figure 18.	NLPID linearized region .....	50
Figure 19.	The DCL_NLPI_C1 architecture .....	55
Figure 20.	DCL_PI2 C1 architecture .....	57
Figure 21.	DCL_DF11 C1, C2, & L1 architecture .....	60
Figure 22.	DCL_DF13 C1, C4, & L1 architecture .....	64
Figure 23.	DCL_DF13 C2, C3, C5, C6, L2, & L3 architecture .....	65
Figure 24.	DCL_DF13 data & coefficient layout .....	66
Figure 25.	DCL_DF22 C1, C4, L1, & L4 architecture .....	73
Figure 26.	DCL_DF22 C2, C5, & L2 architecture .....	74
Figure 27.	DCL_DF22 C3, C6, & L3 architecture .....	74
Figure 28.	DCL_DF23 C1, C4, & L1 architecture .....	82
Figure 29.	DCL_DF23 C2, C5, & L2 architecture .....	82
Figure 30.	DCL_DF23 C3, C6, & L3 architecture .....	83
Figure 31.	DCL_PID32 A1 architecture .....	90
Figure 32.	DCL_PI A1 architecture .....	93
Figure 33.	DCL_GSM sector numbering .....	95
Figure 34.	Data log pointer allocation .....	107
Figure 35.	MLOG architecture .....	112
Figure 36.	TCM operation in TCM_idle mode .....	115
Figure 37.	TCM operation in TCM_armed mode .....	116
Figure 38.	TCM operation in capture mode (monitor frame un-winding) .....	117
Figure 39.	TCM operation in TCM_capture mode (lead frame complete) .....	117
Figure 40.	TCM capture complete .....	118
Figure 41.	Transient servo error .....	120
Figure 42.	FDLOG64 pointer allocation .....	129
Figure 43.	Smith Predictor control loop .....	144

---

---

# Tables

---

---

---

Table 1.	CPU compatibility - controllers .....	6
Table 2.	CPU compatibility – support modules.....	7
Table 3.	Controller execution & code size benchmarks.....	7
Table 4.	Support function execution benchmarks.....	10
Table 5.	Fast update function execution benchmarks .....	11
Table 6.	Double precision function execution benchmarks (no optimization) .....	13
Table 7.	Double precision function execution benchmarks (-o2 optimization) .....	13
Table 8.	List of DCL header files .....	14
Table 9.	List of DCL source files .....	15
Table 10.	List of DCL code examples.....	16
Table 11.	List of fast parameter update function execution cycles .....	23
Table 12.	List of CSS enumerated error codes .....	23
Table 13.	Data log read/write benchmarks .....	108
Table 14.	Performance index function benchmarks.....	121
Table 15.	FDLOG64 read/write benchmarks.....	129



# Introduction

---

---

---

This chapter contains a brief introduction to the Texas Instruments C2000 Digital Control Library (DCL).

### Section

**1.1 Supported Devices**

**1.2 Overview of the Library**

**1.3 New in this Version**

**1.4 Benchmarks**

## 1.1 Supported Devices

The DCL is compatible with four different C2000 CPUs:

- A 64-bit floating point CPU, denoted “FPU64”
- A 32-bit floating point CPU with trigonometric accelerator, denoted “FPU32”
- A 32-bit floating point “Control Law Accelerator”, denoted “CLA”
- A 32-bit fixed point CPU, denoted “C28x”

Controller functions contain a suffix which identifies which CPU they are intended to be used with (see section 1.3.3). The following list provides an overview of the CPU availability on each class of C2000 device. Users should consult the datasheet for their chosen device to determine which CPU combination is present.

The FPU64 can be found on F2838x devices.

Among those devices which contain an FPU32 are:

- TMS320F28002x
- TMS320F28004x
- TMS320F2838x
- TMS320F2837x
- TMS320F2807x
- TMS320F2833x
- TMS320C2834x

- TMS320F2806x
- TMS320F28M35x
- TMS320F28M36x

Some FPU32 devices also contain a Trigonometric Math Unit (TMU) which extends the instruction set to provide support for trigonometric and other math operations. The DCL makes use of the TMU wherever possible. Refer to the controller descriptions for more information.

The library also includes functions optimized for use on the Control Law Accelerator (CLA). This CPU is only found on certain C2000 devices, including:

- TMS320F28004x
- TMS320F2838x
- TMS320F2837x
- TMS320F2807x
- TMS320F2806x
- TMS320F2805x
- TMS320F2803x

The DCL includes limited support for fixed-point C28x platforms in the form of two controllers and two data logging modules. Among the devices supported in this way are:

- TMS320F2805x
- TMS320F2804x
- TMS320F2803x
- TMS320F2802x
- TMS320F281x
- TMS320F280x

Fixed-point (C28x) DCL library functions will also run un-modified on any device which contains an FPU32. The DCL does not support the C24x CPU.

The C28x Run Time Support (RTS) library allows FPU32 functions written in C to be run on the fixed point C28x, however RTS emulation of the floating point data type is not cycle efficient and the library has not been tested in this way. Users are advised to run only those controller and CPU combinations recommended in this User's Guide. A list of controllers and compatible CPUs can be found in Table 1.

## 1.2 Overview of the Library

The C2000 Digital Control Library (DCL) provides a suite of robust software functions for developers of digital control applications using the Texas Instruments C2000 MCU. All functions in the library are supplied in the form of C or assembly source code. There is no object code in the library. The library is deployed in the C2000Ware software suite, which is available for free download at: [www.ti.com/tool/c2000ware](http://www.ti.com/tool/c2000ware).

The DCL functions are intended for use in any system in which a C2000 device is used. The DCL may not be used with any other devices. Refer to the C2000Ware license agreement for further information.



The DCL is independent of other application specific C2000 software libraries and Software Development Kits (SDKs), however providing attention is paid to data type and numerical range, integration with those packages is straightforward.

The DCL contains PID and “Direct Form” controller types. The former are typically used to tune properties of a transient response, while the latter are typically used to shape the open loop frequency response. The DCL contains functions to convert controller parameters from one type to the other; for example, the user may emulate PID control using a direct form 2 controller structure. The library also contains a gain scheduler module.

Supporting functions include: data logging, performance measurement, transient capture, and reference generation. Support functions run on the C28x, FPU32, or FPU64 only; they not compatible with the CLA. Most are supplied in C code form; however a small number of time-critical functions are also supplied as C callable assembly functions.

The library includes a set of example projects which illustrate how DCL functions might be applied in a user project. The library itself contains no device specific code and users of other C2000 devices will find it straightforward to apply the examples to their own projects.

The DCL does not contain tools to measure frequency response or perform compensator parameter selection; however similar features can be found in the “Compensation Designer” utility which is part of the TI “powerSUITE” package. A Software Frequency Response Analyzer (SFRA) utility can be found at: [www.ti.com/tool/sfra](http://www.ti.com/tool/sfra).

## 1.3 New In This Version

### 1.3.1 New Features

Version 3.4 of the DCL adds a reference generator module. The module is documented in a separate user’s guide which can be found in the \docs sub-directory of the DCL installation path.

Also added in version 3.4 is support for the DF22 compensator in double precision floating point. The controller is designated DF22F64 and more information can be found in chapter 3. A double precision clamp has also been added to support this controller.

The macro `DCL_CLEAR_ERROR_CODE` has been added to `DCL.h` to set the stored error in the CSS sub-structure to `ERR_NONE`.

Controller update and run functions which are coded as static inline are now placed in the “`dclfuncs`” section using a `CODE_SECTION` pragma. This allows time critical functions to be copied into RAM at run-time. This change has been made to the files: `DCLF32.h`, `DCLF64.h`, and `DCL_NLPID.h`. Some functions in the new reference generator module are also placed in this section.

Library break-points now insert the `ESTOP0` assembly instruction instead of `NOP`. This instruction inserts a software break-point so the user no longer has to manually set a break-point in CCS. In stand-alone mode, `ESTOP0` is replaced by a `NOP` instruction. As before, break-points can be disabled by commenting out the definition of `DCL_BREAK_POINTS_ENABLED` in `DCL.h`.

The C code in `DCL_error.c` has been simplified. This code is intended for users to modify to implement their own custom error handlers.

The code in DCL\_NLPID\_C3.asm has been slightly modified. An attempt to build a project with this module included but without TMU support will now generate an error (rather than a warning) at compile time.

### 1.3.2 Bug Fixes

Starting from version 3.4, the controller reset functions will no longer clear the error code in the CSS. This makes the reset functions compatible with situations in which the user does not wish to use the support sub-structures.

### 1.3.3 Function Naming

No changes have been made to the function naming convention from v3.3.

The naming convention allows several controllers of similar type, but with different implementations, to be used together in the same program without conflict. An example of a library function name, together with a description of the constituent fields, is shown below.

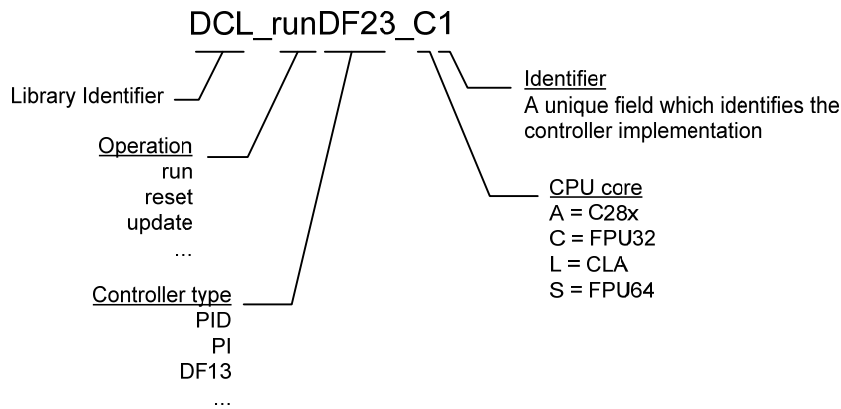

Figure 1. DCL function naming

In this format, both the controller type and the CPU on which it runs are explicit. This allows future expansion of the library with variations of each controller type. An example is the PID controller, which exists in both “ideal” and “parallel” forms in the library. The final digit is an arbitrary number which identifies the implementation. Users may add their own controller variations to the DCL controllers by changing the final two characters of the function name. Refer to section 2.6 for further information.

In addition to “run”, all control structures have associated “reset” and “update” functions. The first resets all internal non-parametric data to its default values without changing any controller parameters. The second performs a safe parameter update without changing any non-parametric control data. Note that the “update” function requires both SPS and CSS structures. The same “verb-noun” function name construction shown in Figure 1 applies to all supporting functions.

The DCL includes an implementation of a 64-bit floating point PID controller. This controller uses the letter “S” as the CPU identifier to distinguish it from the similar FPU32 controllers. It may be compiled and run on an FPU32, however without hardware support

for the double precision data type relatively poor cycle performance should be expected. Refer to Table 6 and Table 7 for further information.

### 1.3.4 Structure Naming

No changes have been made to the structure naming convention from v3.3.

### 1.3.5 Support Sub-structures

Each controller structure contains two 32-bit pointers, each of which holds the address of a separate support sub-structure.

The first such sub-structure contains a Shadow Parameter Set (SPS), which the user loads prior to executing a parameter update sequence. The update sequence performs a safe copy of the SPS parameters into the main controller structure by disabling interrupts before the copy sequence and re-enabling them afterwards. This ensures the controller never runs with a partially updated parameter set, and allows controller parameters to be updated without disturbing the control loop.

The second sub-structure is a Common Support Structure (CSS). The CSS contains supporting data used for error checking and parameter updates.

The use of SPS and CSS is optional. Users who do not need the additional features provided by SPS and CSS may safely ignore these structures.

### 1.3.6 Calling Convention

All functions in the DCL are designed to be called from a C program. The context save & restore in each function assumes the standard parent register save is performed by the compiler. If any of the assembly functions are called from an assembly program, additional context save & restore instructions must be added by the user. See section 2.2.2 for further details.

### 1.3.7 Data Types

Library floating-point variables are declared with either the `float32_t` or the `float64_t` data type. Unsigned and signed integers are declared as `uint16_t` and `int16_t` respectively. Fixed-point controllers use the signed long integer type `int32_t`. Data type definitions can be found in the `DCL.h` header file. The DCL is compatible with both COFF and EABI compilers.

### 1.3.8 The ZPK3 Structure

The library header file `DCL.h` contains a type definition of a third order transfer function in the form of zero and pole frequencies, and a real gain. This “ZPK3” structure enables direct form compensators to be configured from specifications involving pole and zero frequencies. Functions also exist to load PI and PID controllers in the same way. Refer to chapter 3 for more information on controller configuration using ZPK3.

The general form of the linear third order DT transfer function is

$$\text{Equation 1. } F(z) = K \frac{(z-q1)(z-q2)(z-q3)}{(z-p1)(z-p2)(z-p3)}$$

In Equation 1,  $q_1$ ,  $q_2$ , and  $q_3$ , represent the frequencies of the three zeros in Hz;  $p_1$ ,  $p_2$ , and  $p_3$  represent the frequencies of the three poles in Hz; and  $K$  is the real gain.

The ZPK3 structure is also used in the library to represent first and second order transfer functions. In each case, poles and zeros on the right being ignored. For example, in a 1-pole, 1-zero description, only  $K$ ,  $q_1$ , and  $p_1$  are relevant; the user function will ignore  $q_2$ ,  $q_3$ ,  $p_2$ , &  $p_3$ .

The DCL functions which take ZPK3 arguments allow complex poles and zeros providing they exist in conjugate pairs, thereby resulting in real polynomial coefficients. Error checking is built into those functions to ensure this is always the case.

### 1.3.9 Compensator Stability Tests

The library contains functions to test stability of all direct form compensators. Stability is determined from the pole locations based on the transfer function denominator coefficients. Generic polynomial stability functions are found in the library header file `DCL.h`. In the first order case, determination is trivial. For second and third order compensators, the Jury array method is used. All stability test functions return the `bool` data type: 'true' if all compensator poles lie within the unit circle, otherwise 'false'.

### 1.3.10 Deprecated Modules

All multi-channel data loggers (MLOG & MLOG32) will be removed in a future version of the library.

## 1.4 CPU Compatibility

The tables below list the CPU compatibility of the controller and support structures in the DCL.

Table 1. CPU compatibility - controllers

Controller	C28x	FPU32	FPU64	CLA
DCL_PID	No	Yes	No	No
DCL_PI	No	Yes	No	No
DCL_PI2	No	Yes	No	No
DCL_NLPID	No	Yes	No	No
DCL_NLPI	No	Yes	No	No
DCL_DF11	No	Yes	No	No
DCL_DF13	No	Yes	No	No
DCL_DF22	No	Yes	No	No
DCL_DF23	No	Yes	No	No

<b>DCL_GSM</b>	No	Yes	No	No
<b>DCL_PID_CLA</b>	No	No	No	Yes
<b>DCL_PI_CLA</b>	No	No	No	Yes
<b>DCL_DF11_CLA</b>	No	No	No	Yes
<b>DCL_DF13_CLA</b>	No	No	No	Yes
<b>DCL_DF22_CLA</b>	No	No	No	Yes
<b>DCL_DF23_CLA</b>	No	No	No	Yes
<b>DCL_PID32</b>	Yes	No	No	No
<b>DCL_PI32</b>	Yes	No	No	No
<b>DCL_PIDF64</b>	No	Yes	Yes	No

Table 2. CPU compatibility – support modules

<b>Controller</b>	<b>C28x</b>	<b>FPU32</b>	<b>FPU64</b>	<b>CLA</b>
<b>FDLOG</b>	No	Yes	No	No
<b>MLOG</b>	No	Yes	No	No
<b>TCM</b>	No	Yes	No	No
<b>FDLOG32</b>	Yes	No	No	No
<b>MLOG32</b>	Yes	No	No	No
<b>FDLOG64</b>	No	Yes	Yes	No

## 1.5 Benchmarks

### 1.5.1 Controller Benchmarks

Table 3 lists the performance of each library function by cycle count and code size. In all cases, cycle count benchmarks were measured by logging a free-running PWM timer before and after each function call. Therefore the measured cycle count includes the function calling overhead from the C environment. In cases where the cycle count is dependent on input data, such as in anti-windup logic, the maximum figure is always given. Compiler optimization was disabled in all tests. Function sizes are given in units of 16-bit words, as reported in the “.map” file.

Table 3. Controller execution & code size benchmarks

<b>Function</b>	<b>Cycles</b>	<b>Size (W)</b>
DCL_runPID_A1	99	80

DCL_runPID_C1	83	99
DCL_runPID_C2	197	207
DCL_runPID_C3	186	196
DCL_runPID_C4	86	92
DCL_runPID_L1	53	70
DCL_runPID_L2	45	58
DCL_runPI_A1	62	46
DCL_runPI_C1	52	54
DCL_runPI_C2	117	121
DCL_runPI_C3	122	126
DCL_runPI_C4	48	37
DCL_runPI_C5	194	180
DCL_runPI_C6	140	133
DCL_runPI_C7	51	40
DCL_runPI_L1	34	42
DCL_runPI_L2	33	40
DCL_runPI_L3	118	238
DCL_runPI_L4	122	248
DCL_runPI_L5	138	272
DCL_runNLPID_C1	284 <sup>(1)(2)</sup>	312
DCL_setGamma	2090 <sup>(2)</sup>	
DCL_runNLPID_C2	3353 <sup>(1)</sup>	3297 <sup>(1)</sup>
DCL_runNLPID_C3	117	185
DCL_runNLPID	2230 <sup>(1)</sup>	2197 <sup>(1)</sup>
DCL_runPI2_C1	218	201
DCL_runDF11_C1	37	23
DCL_runDF11_C2	60	
DCL_runDF11_L1	30	34
DCL_runDF13_C1	71	66
DCL_runDF13_C2	20	79
DCL_runDF13_C3	74	
DCL_runDF13_C4	175	162
DCL_runDF13_C5	40	38
DCL_runDF13_C6	121	126
DCL_runDF13_L1	61	86
DCL_runDF13_L2	20	100
DCL_runDF13_L3	58	
DCL_runDF22_C1	44	45
DCL_runDF22_C2	19	48
DCL_runDF22_C3	39	
DCL_runDF22_C4	71	75

DCL_runDF22_C5	29	26
DCL_runDF22_C6	60	67
DCL_runDF22_L1	33	40
DCL_runDF22_L2	20	60
DCL_runDF22_L3	34	
DCL_runDF22_L4	83	146
DCL_runDF23_C1	62	64
DCL_runDF23_C2	20	69
DCL_runDF23_C3	54	
DCL_runDF23_C4	98	107
DCL_runDF23_C5	29	26
DCL_runDF23_C6	82	97
DCL_runDF23_L1	44	60
DCL_runDF23_L2	20	80
DCL_runDF23_L3	44	
DCL_runGSM_C1	50	TBD
DCL_runNLF_C1	1075 <sup>(1)</sup>	1075 <sup>(1)</sup>
DCL_runPIDF64_S1 <sup>(4)</sup>	2840	310
DCL_writeLog	48	N/A
DCL_readLog	39	N/A
DCL_freadLog	22	11
DCL_fwriteLog	22	14
DCL_runClamp_C1	28	20
DCL_runClamp_C2	71	
DCL_runClamp_L1	25	26
DCL_runITAE_C1	<sup>(3)</sup>	60
DCL_runIAE_C1	<sup>(3)</sup>	
DCL_runIES_C1	<sup>(3)</sup>	

<sup>(1)</sup> All paths operating in linearized error region. For all paths in non-linear operation, total cycle count is approximately 1,433. See section 3.3.1 for more information.

<sup>(2)</sup> Measured with run-time library support for the `powf()` function.

<sup>(3)</sup> Cycle count depends on buffer length. Refer to section 3.4.1 for more information.

<sup>(4)</sup> Refer to Table 6.

### 1.5.2 Controller Support Function Benchmarks

The table below shows execution benchmarks for the supporting functions new in v3.0 of the DCL. Execution figures include C function calling overhead. Separate measurements are given for update performed and not performed according to the `sts` flag status (see section 2.4). In all cases, compiler optimization was turned off.

Table 4. Support function execution benchmarks

Function	File	Cycles <sup>(1)</sup>	Cycles <sup>(2)</sup>
DCL_resetPID	DCLF32.h	85	85
DCL_updatePID	DCLF32.h	964 / 796	201 / 33
DCL_setPIDfilterBW	DCLF32.h	1060	771
DCL_getPIDfilterBW	DCLF32.h	509	509
DCL_loadSeriesPIDasZPK	DCLF32.h	3226	2939
DCL_loadParallelPIDasZPK	DCLF32.h	2741	2454
DCL_resetPI	DCLF32.h	71	71
DCL_updatePI	DCLF32.h	326 / 191	166 / 33
DCL_loadSeriesPIasZPK	DCLF32.h	668	306
DCL_loadParallelPIasZPK	DCLF32.h	433	71
DCL_resetPI2	DCLCLA.h	82	82
DCL_updatePI2	DCLCLA.h	267 / 179	131 / 33
DCL_resetDF11	DCLF32.h	71	71
DCL_updateDF11	DCLF32.h	113 / 33	113 / 33
DCL_isStableDF11	DCLF32.h	62 / 62	62 / 62
DCL_loadDF11asPI	DCLF32.h	611	548
DCL_loadDF11asZPK	DCLF32.h	291	102
DCL_resetDF13	DCLF32.h	110	110
DCL_updateDF13	DCLF32.h	200 / 33	201 / 33
DCL_isStableDF13	DCLF32.h	1532 / 1524	1532 / 1524
DCL_loadDF13asZPK	DCLF32.h	5333	4962
DCL_resetDF22	DCLF32.h	72	72
DCL_updateDF22	DCLF32.h	144 / 33	144 / 33
DCL_isStableDF22	DCLF32.h	794	794 / 793
DCL_loadDF22asZPK	DCLF32.h	1419	1155
DCL_loadDF22asZwn	DCLF32.h	465	406
DCL_loadDF22asParallelPID	DCLF32.h	1208	826
DCL_loadDF22asSeriesPID	DCLF32.h	1191	823
DCL_resetDF23	DCLF32.h	78	78
DCL_updateDF23	DCLF32.h	182 / 33	182 / 33
DCL_loadDF23asZPK	DCLF32.h	7138	4950
DCL_isStableDF23	DCLF32.h	1531 / 1516	1531 / 1516
DCL_resetPID32	DCL32.h	52	52
DCL_updatePID32	DCL32.h	154 / 34	154 / 34
DCL_resetPI32	DCL32.h	32	32
DCL_updatePI32	DCL32.h	103 / 34	103 / 34
DCL_resetGSM	DCL.h	327	327
DCL_updateGSM	DCL.h	504 / 33	504 / 33



DCL_loadGSMgains	DCL.h	389	389
DCL_loadGSMoffsets	DCL.h	501	501
DCL_runGSM_C1	DCL.h	73 / 52	73 / 52
DCL_fupdatePID	DCL_futils.asm	77 / 37	N/A
DCL_fupdatePI	DCL_futils.asm	64 / 37	N/A
DCL_fupdatePI2	DCL_futils.asm	57 / 37	N/A
DCL_fupdateDF11	DCL_futils.asm	58 / 37	N/A
DCL_fupdateDF13	DCL_futils.asm	78 / 37	N/A
DCL_fupdateDF22	DCL_futils.asm	66 / 37	N/A
DCL_fupdateDF23	DCL_futils.asm	74 / 37	N/A
DCL_fupdateGSM	DCL_futils.asm	114 / 37	N/A
DCL_fupdatePID32	DCL_futils32.asm	73 / 37	N/A
DCL_fupdatePI32	DCL_futils32.asm	57 / 37	N/A
DCL_resetNLPID	DCL_NLPID.h	84	85
DCL_updateNLPID	DCL_NLPID.h	1190 / 871	353 / 33
DCL_setNLPIDfilterBW	DCL_NLPID.h	1066	771
DCL_setActiveNLPIDfilterBW	DCL_NLPID.h	1028	743
DCL_getNLPIDfilterBW	DCL_NLPID.h	509	509
DCL_getNLPIDgamma	DCL_NLPID.h	998	999
DCL_getNLPIDdelta	DCL_NLPID.h	1273	1274
DCL_setNLPIDgamma	DCL_NLPID.h	3284	3057
DCL_getNLFgamma	DCL_NLPID.h	995	995
DCL_setActivePIDfilterBW	DCLF32.h	1027	743
DCL_resetPIDF64	DCLF64.h	106	106
DCL_updatePIDF64	DCLF64.h	546 / 35	237 / 33
DCL_setPIDF64filterBW	DCLF64.h	10599	8132
DCL_setActivePIDF64filterBW	DCLF64.h	10503	7982
DCL_getPIDF64filterBW	DCLF64.h	5163	5135

<sup>(1)</sup> Built with no optimization and error checking enabled.

<sup>(2)</sup> Built with no optimization and error checking disabled.

### 1.5.3 Fast Update Function Benchmarks

The table below shows execution benchmarks for the fast update functions of the DCL. All functions are implemented in assembly code. The right-most column shows the number of CPU clock cycles for which global interrupts are disabled while the copy takes place. Interrupts are not disabled if an update is not pending and no update is performed.

Table 5. Fast update function execution benchmarks

Function	File	Cycles (update)	Cycles (no update)	Interrupts blocked (cycles)
----------	------	--------------------	-----------------------	--------------------------------

DCL_fupdatePID	DCL_futils.asm	77	37	37
DCL_fupdatePI	DCL_futils.asm	64	37	24
DCL_fupdatePI2	DCL_futils.asm	57	37	17
DCL_fupdateDF11	DCL_futils.asm	58	37	31
DCL_fupdateDF13	DCL_futils.asm	78	37	38
DCL_fupdateDF22	DCL_futils.asm	66	37	26
DCL_fupdateDF23	DCL_futils.asm	74	37	34
DCL_fupdateGSM	DCL_futils.asm	114	37	74
DCL_fupdatePID32	DCL_futils32.asm	73	37	33
DCL_fupdatePI32	DCL_futils32.asm	57	37	17

### 1.5.4 FPU64 Function Benchmarks

The following two tables show execution benchmarks in CPU cycles for the double precision floating point functions of the DCL. In each case, figures for “fpu32” and “fpu64” settings of the “—float\_support” compiler option are shown. The right-most column shows the percentage reduction in cycle count resulting from hardware support of the double precision data type.

Table 6. Double precision function execution benchmarks (no optimization)

Function	fpu32	fpu64	Reduction (%)
DCL_setPIDF64filterBW	8090	174	97.85
DCL_updatePIDF64	251	241	3.98
DCL_updatePIDF64	55	55	0.00
DCL_getPIDF64filterBW	5180	124	97.61
DCL_setActivePIDF64filterBW	7998	154	98.07
DCL_resetPIDF64	127	110	13.39
DCL_runPIDF64	2840	275	90.32
DCL_fillLog64 <sup>(1)</sup>	573	534	6.81
DCL_writeLog64	96	80	16.67
DCL_readLog64	78	66	15.38

<sup>(1)</sup> Data log size = 21 elements.

Table 7. Double precision function execution benchmarks (-o2 optimization)

Function	fpu32	fpu64	Reduction (%)
DCL_setPIDF64filterBW	5141	76	98.52
DCL_updatePIDF64	121	105	13.22
DCL_updatePIDF64	22	22	0.00
DCL_getPIDF64filterBW	5104	74	98.55
DCL_setActivePIDF64filterBW	15	8	46.67
DCL_resetPIDF64	35	35	0.00
DCL_runPIDF64	2693	98	96.36
DCL_fillLog64 <sup>(1)</sup>	443	443	0.00
DCL_writeLog64	32	30	6.25
DCL_readLog64	32	26	18.75

<sup>(1)</sup> Data log size = 21 elements.

# Using the Digital Control Library

---



---



---

This chapter describes how to use the Digital Control Library.

## Section

- 2.1 What the Library Contains
- 2.2 Header File Dependency
- 2.3 How to Add the DCL to User Code
- 2.4 Updating Controller Parameters
- 2.5 Error Handling
- 2.6 How to Modify the Library Code

## 2.1 What the Library Contains

The DCL library is supplied entirely in source code form; there are no object or “.lib” files in the library. This allows the user to modify the library controller functions, or to add their own functions if different functionality is required. Controller functions are supplied in the following formats.

- Inline C code
- FPU32 assembly code
- C28x assembly code
- CLA assembly code

### 2.1.1 Header Files

The following header files are included in the library.

Table 8. List of DCL header files

Filename	Type	Description
DCL	h	Common library definitions
DCLF32	h	FPU32 controller functions
DCLF64	h	Double precision controller functions
DCLCLA	h	CLA controller functions

DCLC28	h	C28x fixed point controller functions
DCL_NLPID	h	FPU32 non-linear PID
DCL_MLOG	h	Four channel FPU32 data logger
DCL_fdlog	h	FPU32 data logger
DCL_fdlog64	h	Double precision data logger
DCL_TCM	h	FPU32 Transient Capture Module
DCL_log32	h	C28x data logger functions
DCL_MLOG32	h	C28x four channel data logger

### 2.1.2 Source Files

The following source files are included in the library.

Table 9. List of DCL source files

Filename	Type	CPU	Description
DCL_PID_A1	asm	C28x	Fixed-point linear PID
DCL_PID_C1	asm	FPU32	Ideal linear PID
DCL_PID_C4	asm	FPU32	Parallel linear PID
DCL_PID_L1	asm	CLA	Ideal linear PID
DCL_PID_L2	asm	CLA	Parallel linear PID
DCL_PI_A1	asm	C28x	Fixed-point linear PI
DCL_PI_C1	asm	FPU32	Ideal linear PI
DCL_PI_C4	asm	FPU32	Parallel linear PI
DCL_PI_C7	asm	FPU32	Parallel linear PI (Tustin)
DCL_PI_L1	asm	CLA	Ideal linear PI
DCL_PI_L2	asm	CLA	Parallel linear PI
DCL_NLPID_C3	asm	FPU32 <sup>(1)</sup>	Nonlinear PID
DCL_DF11_C1	asm	FPU32	Full DF1 (1 <sup>st</sup> order)
DCL_DF11_L1	asm	CLA	Full DF1 (1 <sup>st</sup> order)
DCL_DF13_C1	asm	FPU32	Full DF1 (3rd order)
DCL_DF13_C2C3	asm	FPU32	Pre-computed DF1 (3rd order)
DCL_DF13_L1	asm	CLA	Full DF1 (3rd order)
DCL_DF13_L2L3	asm	CLA	Pre-computed DF1 (3rd order)
DCL_DF22_C1	asm	FPU32	Full DF2 (2nd order)
DCL_DF22_C2C3	asm	FPU32	Pre-computed DF2 (2nd order)
DCL_DF22_L1	asm	CLA	Full DF2 (2nd order)
DCL_DF22_L2L3	asm	CLA	Pre-computed DF2 (2nd order)
DCL_DF23_C1	asm	FPU32	Full DF2 (3rd order)
DCL_DF23_C2C3	asm	FPU32	Pre-computed DF2 (3rd order)
DCL_DF23_L1	asm	CLA	Full DF2 (3rd order)
DCL_DF23_L2L3	asm	CLA	Pre-computed DF2 (3rd order)
DCL_frwlog	asm	FPU32	Fast read/write log functions
DCL_clamp_C1	asm	FPU32	Data clamp
DCL_clamp_L1	asm	CLA	Data clamp

DCL_index	asm	FPU32	Performance measurement
DCL_error	C	FPU32	Template error handler
DCL_futils	asm	FPU32	Fast parameter updates
DCL_futils32	asm	C28x	Fast parameter updates

<sup>(1)</sup> Requires TMU type 1. Refer to device datasheet for more information.

### 2.1.3 Examples

A set of code examples is supplied with the Digital Control Library. These were prepared using CCS version 8.3.0 and run without modification on either the F28069, F280049, or F28388D device. The examples include linker command files which show how to allocate device memory when using the DCL. Further details can be found in Chapter 5.

Table 10. List of DCL code examples

Example	Description	Core	Device
1	DF22 compensator	FPU32	F28069
2	DF32 compensator	CLA	F28069
3	NLPID controller	FPU32	F28069
4	PI controller	CLA	F28069
5	PID controller	FPU32	F28069
6	TCM	FPU32	F28069
7	Smith predictor	FPU32	F28069
8	Gain scheduler	FPU32	F28069
9	Multiple control loops + ERAD	FPU32	F280049
10	PID controller	FPU64	F28388D
11	NLPID controller	FPU32	F280025

## 2.2 Header File Dependency

In the DCL, the file `DCL.h` is a central repository of common data types and sub-structure definitions. The naming convention in the DCL is that header files which contain basic controller functions for a specific CPU are named "`DCLxyz.h`", where "`xyz`" identifies the CPU designator and there is no underscore. Header files which contain specific controllers or utilities have an underscore immediately following the library designator, for example "`DCL_NLPID.h`". Header file dependency is shown diagrammatically below.

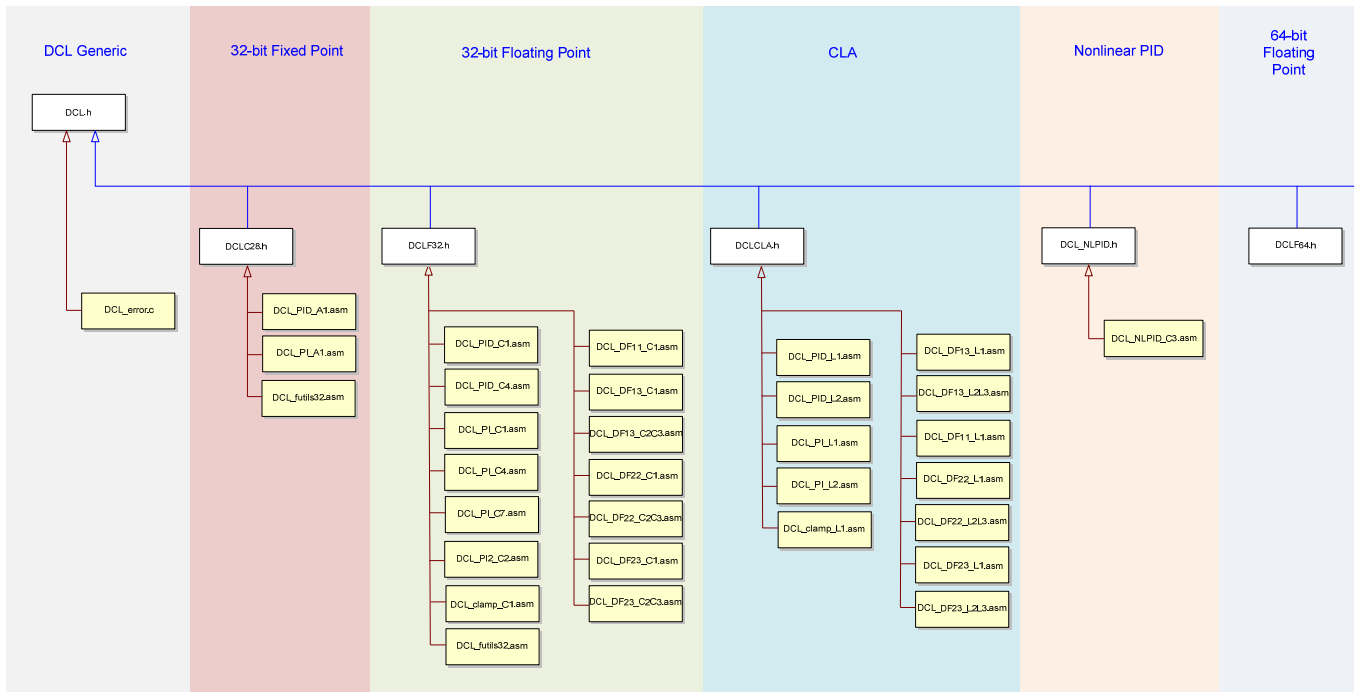

Figure 2. DCL Controller Header File Dependency

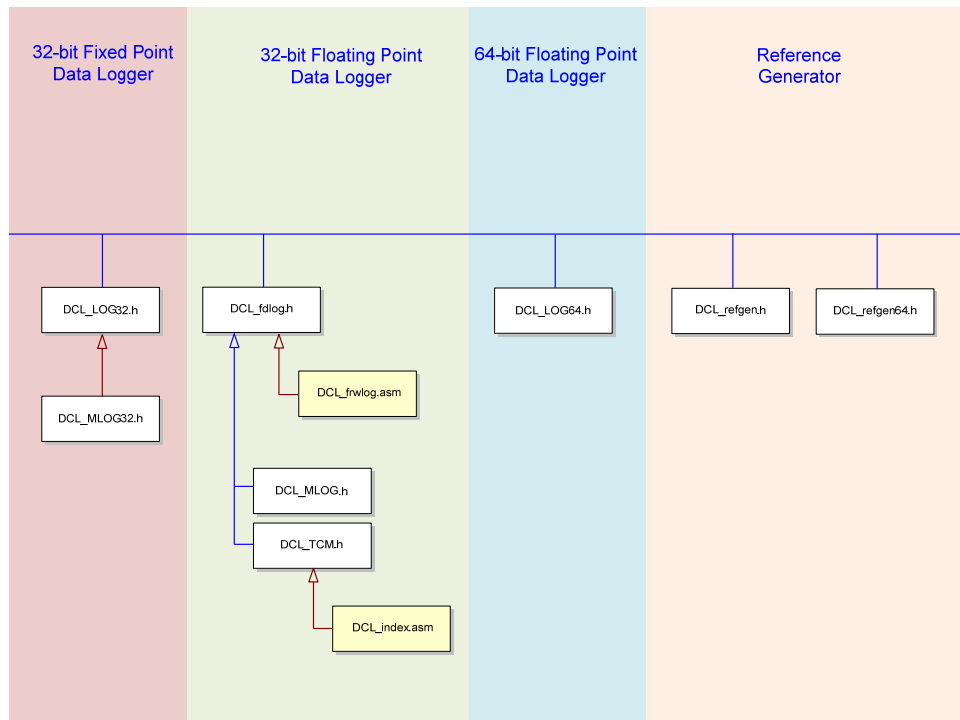

Figure 3. DCL Data Logger Header Dependency

## 2.3 How to Add the DCL to User Code

The Digital Control Library is intended to be used with a CCS project written in the C programming language. The user is responsible for initializing elements of the controller structure prior to calling the controller 'run' function. Typically the desired controller functions are inserted into an Interrupt Service Routine (ISR) triggered by a hardware event. This ensures that the controllers are executed at a fixed rate and that their timing is synchronized with the availability of incoming data. Control functions for use on the CLA would be called from a CLA task, which again, would typically be triggered at a fixed rate by a hardware event.

Controller parameters and dynamic data are encapsulated in a C structure, a pointer to which is passed as a parameter to the controller 'run' function. Typically, the controller structure would be a global variable in the user's program and its' contents initialized prior to the first call to the 'run' function. The controller 'run' functions are not re-entrant, since they rely on a global variable (in this case the controller structure). It is the responsibility of the user to ensure that a controller function is not called while a similar controller function is in progress.

### 2.3.1 Steps to Add the DCL to Existing C Code

The following is a recommended sequence of steps to add the DCL to an existing C program. Refer to chapter 5 for code examples which illustrate configuration and use of the DCL with the CLA.

#### Step 1. Specify the include file(s)

Before you can begin using the library you must add the appropriate controller header file to your project.

To use the 32-bit floating-point DCL functions include the file `DCLF32.h`.

```
#include "DCLF32.h"
```

To use fixed-point CLA functions include the file `DCLCLA.h`.

```
#include "DCLCLA.h"
```

To use fixed-point DCL functions include the file `DCLC28.h`.

```
#include "DCLC28.h"
```

To use double precision floating point DCL functions include the file `DCLF64.h`.

```
#include "DCLF64.h"
```

To use any of the nonlinear controllers include the file `DCL_NLPID.h`.

```
#include "DCL_NLPID.h"
```

It is not necessary to explicitly include the common library file `DCL.h` since that file is included in the controller header files above.

CCS must be configured in such a way that the DCL header files are visible to all program source files which reference controller variables or functions. The include file search options in CCS allow users to specify header file paths for each project. In CCS, the



include options can be configured by right-clicking on the project name, selecting “Properties”, and navigating to the “Include Options” section.

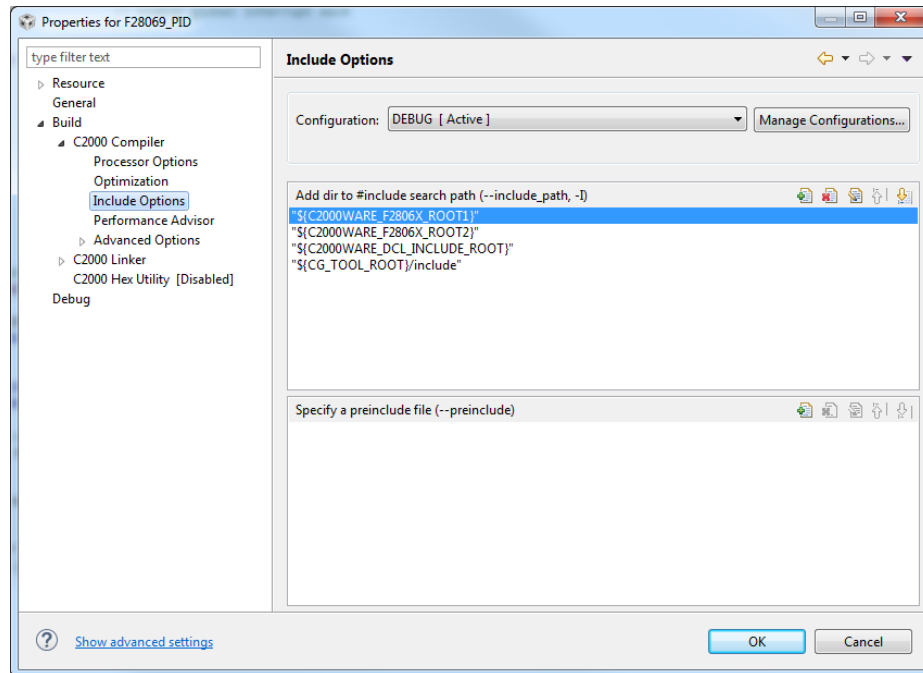

Figure 4. CCSv6 Include Options

If you wish to use the data logger, MLOG, or TCM, you must also include the respective header file(s) (note that the MLOG and TCM modules include the relevant data log header file). Refer to section 2.2 for more information on header file dependency.

### Step 2. Add the source files to the project

If you wish to use any of the assembly coded controllers, the source file(s) for the controller(s) you wish to use must be added to your CCS project. You can manually copy the files into your project directory, or specify the library pathname in the CCS compiler options. Refer to Table 9 for a list of controller source files. It is only necessary to add the source files for those functions you wish to use.

### Step 3. Allocate the controller functions in the linker command file

DCL functions which run on the FPU32 or C28x core can be allocated to a specific memory block in the linker command file. It is common to place the controller functions in zero wait-state internal RAM since this allows them to run at the maximum speed of the device. Note that all CLA functions must run from internal zero wait-state RAM.

All DCL library functions are placed in the user defined code section `.dclfuncs`. An example showing how this section might be mapped into the internal L4 RAM memory block is shown below.

```
dclfuncs          : > RAML4,          PAGE = 0
```

See also the linker command file `F28069_DCL.cmd` in the project examples (chapter 5).

In a stand-alone application, code must be stored in non-volatile memory (such as internal flash) and copied into RAM at run-time. For information on how to do this, refer to the

application note “*Running an Application from Internal Flash Memory on the TMS320F28xxx DSP*”, TI literature number SPRA958.

Information on linker section allocation can be found in the “*TMS320C28x Assembly Language Tools User’s Guide*”.

#### Step 4. Create an instance of the controller

You must declare an instance of the controller you wish to use. For example, to create an initialized instance of a 32-bit floating-point PID controller with the name “pid1”:

```
DCL_PID pid1 = PID_DEFAULTS;
```

This step will create an instance of a PID controller structure the elements of which are loaded with default parameter and data values specified in the file `DCLF32.h`.

Note that CLA variables must be initialized at run-time by user code (i.e. they cannot be initialized at the variable declaration). Typically this is done using a separate CLA task (see code examples 2 & 4).

#### Step 5. Create instances of the support structures (optional)

If you wish to make use of the error checking or safe parameter update features in the library, you must declare instances of both the SPS and CSS sub-structures, and initialize them appropriately. If you do not wish to use these features, this step can be ignored.

To declare an initialized instance of the SPS for the PID controller, you would do the following:

```
DCL_PID_SPS spid = PID_SPS_DEFAULTS;
```

To declare an initialized instance of the CSS for the PID controller, you would do the following:

```
DCL_CSS cpid = DCL_CSS_DEFAULTS;
```

Assign each of the above structures to the PID control structure in step 4.

```
pid1.sps = &spid;
```

```
pid1.css = &cpid;
```

This creates a variable of type “DCL\_PID”, the elements of which are initialized to default values specified in the `DCL.h` header file. Like any C variable, the structure must be visible to any source files which reference it.

Functions which use the update rate of the controller require the “T” element of the CSS sub-structure to be loaded in advance. This can be done using the `DCL_SET_CONTROLLER_PERIOD` macro. For example, an update period of 100 ms would be loaded as follows:

```
DCL_SET_CONTROLLER_PERIOD(pid1, 0.1f);
```

#### Step 6. Declare variables

In addition to a pointer to the controller structure, each DCL controller function requires certain input variables to be passed as arguments to the function, and will return a control output. You should declare instances of these variables in your code and ensure they can be referenced by all files which call the controller functions. For example:

```
float uk;           // control
```

```

float rk = 0.0f;    // reference
float yk = 0.0f;    // feedback
float lk = 1.0f;    // saturation

```

Note that CLA variables cannot be initialized at the declaration. Refer to the CLA code in chapter 5 for examples of how to initialize CLA variables.

### Step 7. Initialize the controller

The elements of the (FPU32 or C28x) controller structure were initialized to default settings in step 3. The user program must configure any controller elements with specific values before the function is called. For example:

```

pid1.Kp = 9.4f;    // set proportional gain to 9.4
pid1.Umax = 10.0f; // upper output clamp limit = 10

```

If a CLA based controller is being used, its parameters must always be initialized using a separate task. For more information on the CLA C compiler, see Chapter 10 of the *"TMS320C28x Optimizing C/C++ Compiler User's Guide"*.

Direct Form control structures incorporate one or two delay lines which hold previous controller data. These must be initialized to zero before calling the controller functions, which can be done with the appropriate "DCL\_reset" function. If this is not done, it is possible that uninitialized delay line data, especially in the recursive path, might cause the controller to saturate or deliver incorrect results. Initialization of the delay line elements is the responsibility of the user. Refer to the code in examples 1 and 2 described in chapter 4 for examples of delay line initialization.

### Step 8. Call the controller function

Typically the controller functions would be inserted into an Interrupt Service Routine (ISR) which is triggered by a hardware timer. Each control function returns a single floating-point variable which represents the controller output. An example of an FPU32 controller function call is shown below.

```

uk = DCL_runPID_C1(&pid1, rk, yk lk);

```

### 2.3.2 Calling the Library Functions from Assembly

The assembly coded functions in the DCL have been written to be called from a C program. The context save and restore sections within each function protect only those core registers which are not already protected by the C environment. In applications where the DCL controller functions must be called from an assembly program, the user must place additional register save and restore instructions near the start end end of each called function.

For the C28x, refer to sections 7.2 and 7.3 of the *"TMS320C28x Optimizing C/C++ Compiler User's Guide"* for detailed information on register usage and calling conventions. For the CLA, refer to section 10.2.4 of the same document.

## 2.4 Updating Controller Parameters

The DCL allows controller parameters to be safely updated "on-the-fly", without stopping the control loop. To accomplish this, the user must declare and initialize the SPS and CSS sub-structures as described in section 2.3.1, step 5.

To update controller parameters, follow these steps:

### Step 1. Load the shadow parameter set

Load all the elements of the SPS sub-structure with the new controller values. Continuing the example in section 2.3.1, one might do this:

```
pid1.sps.Kp = 10.987f;
pid1.sps.Ki = 0.0023f;
```

Ensure all the SPS elements are loaded before performing the update, even if they do not need to change.

### Step 2. Enable the update flag

Set the update flag in the CSS status register to enable the parameter copy on the next call to the update function. There is a C macro in `DCL.h` to do this.

```
DCL_REQUEST_UPDATE(&pid1);
```

This sets the LSB in the status element `sts` in the CSS sub-structure to indicate that an update is pending.

### Step 3. Call the update function

Call the appropriate controller update function. This would typically be done in the background loop.

```
DCL_updatePID(&pid1);
```

This function tests the update flag to determine whether an update is pending. If so, it blocks the device interrupts, performs the shadow to active parameter set copy, re-enables device interrupts, and clears the update request flag previously set in step 1.

In blocking interrupts, the library will save the prior state of the global interrupt flag (INTM) into a local variable. The state is restored when interrupts are re-enabled at the end of the update. In this way, update functions may be called by the user irrespective of whether interrupts are already enabled: the function will not change the prior interrupt state. A similar method of interrupt blocking and protection is implemented in the 'reset' functions to ensure controllers do not run with partially reset internal variables. Interrupt blocking macros and functions can be found in the library header file `DCL.h`.

Updating controller parameters is a time critical task since interrupts must be disabled while copying takes place. For this reason the library includes a set of assembly coded update functions which are used in the same way described above, but which execute faster than their C counterparts and are deterministic. In all cases, the same update function names are pre-fixed with the letter 'f', so the above example becomes

```
DCL_fupdatePID(&pid1);
```

The floating point assembly update routines are contained in the source file `DCL_futils.asm` which must be added to the user's project. At the top of this file is a list of ".set" directives which allows the user to selectively disable those functions which are not required in order to reduce code space.

Fixed point update routines are contained in the file `DCL_futils32.asm`.

The table below lists the fast parameter update functions together with the cycle counts when an update is performed and when the update is by-passed. Also shown are the number of CPU cycles for which global interrupts are masked when the update takes

place. Note that the assembly functions do not perform any error checking prior to the update.

Table 11. List of fast parameter update function execution cycles

Function	Update taken	No update	Interrupts blocked
DCL_fupdatePID	77	37	37
DCL_fupdatePI	64	37	24
DCL_fupdatePI2	57	37	17
DCL_fupdateDF11	58	37	31
DCL_fupdateDF13	78	37	38
DCL_fupdateDF22	66	7	26
DCL_fupdateDF23	74	37	34
DCL_fupdateGSM	114	37	74
DCL_fupdatePID32	73	37	33
DCL_fupdatePI32	57	37	17

## 2.5 Error Handling

The DCL contains limited support for error detection and handling. Many of the supporting functions perform range checks on parameters and input variables to ensure they fall within allowable ranges. These checks consume cycles, and in performance critical situations the user may elect to disable error checking by commenting out the following line in `DCL.h`.

```
#define DCL_ERROR_HANDLING_ENABLED
```

Users should inspect the source code for the relevant functions to determine which checks are performed.

If an error is detected, the code will set the “`err`” field of the CSS sub-structure of the controller with an error code. An enumerated list of error codes can be found in `DCL.h`.

Table 12. List of CSS enumerated error codes

Name	Description
ERR_NONE	No error present.
ERR_PARAM_RANGE	A parameter was passed to a function, or a controller element found, which lay outside its allowable range.
ERR_PARAM_INVALID	An invalid parameter was passed to a DCL function.

ERR_PARAM_WARN	A non-critical parameter error was found.
ERR_INPUT_RANGE	An input was supplied which lies outside the allowable range.
ERR_OVERFLOW	A variable exceeded its' allowable range.
ERR_UNDERFLOW	A variable was below its' allowable range.
ERR_VERSION	The version of the DCL is incorrect.
ERR_DEVICE	A function was called which requires hardware features not present on the selected device.
ERR_CONTROLLER	A control operation was called before the same operation had completed.
ERR_TIMING	A timing error has occurred.
ERR_COMPUTATION	A computation error has occurred.

After each test sequence, if the `err` field is non-zero, the code will load the source line number of the error and call an error handler function using the following C macros.

```
if (p->css->err)
{
    DCL_GET_ERROR_LOC(p->css);
    DCL_RUN_ERROR_HANDLER(p->css);
}
```

The default error handler function is located in the source file `DCL_error.c`. The DCL does not perform sophisticated error handling, however the user is free to add their own code to this file, or to re-direct the error handler to their own custom error function if desired. Note that the enumerated error list is likely to be appended in future versions of the library.

Among those errors in the standard enumerated list is `ERR_CONTROLLER`. This error is used to detect over-run conditions, where a non-atomic controller function fails to complete before being called again. This is potentially dangerous since the second call will run with a partially updated data set. To detect this condition, the file `DCL.h` defines the macros `DCL_CONTROLLER_BEGIN` and `DCL_CONTROLLER_END` which the user may place at the start and end of a controller function to set and clear respectively the `STS_CONTROLLER_RUNNING` bit in the `STS` field of the `CSS` sub-structure. This can be examined inside the function to detect a partially complete control operation as follows.

At the start of the controller function: check whether the `STS_CONTROLLER_RUNNING` bit is set, then set it.

```
p->css->err |= (p->css->sts & STS_CONTROLLER_RUNNING) ? ERR_CONTROLLER :
ERR_NONE;
if (p->css->err)
{
    DCL_GET_ERROR_LOC(p->css);
    DCL_RUN_ERROR_HANDLER(p->css);
}
DCL_CONTROLLER_BEGIN(p);
```

At the end of the controller function: clear the STS\_CONTROLLER\_RUNNING bit.

```
DCL_CONTROLLER_END(p);
```

In the above code, `p` represents a pointer to the controller structure. Refer to the controller code in `DCL_NLPID.h` for examples of the above method.

## 2.6 How to Modify the Library Code

The DCL is supplied entirely in source code form so it is possible (indeed, encouraged) for users to modify the functions freely to meet specific needs or improve performance. However, the library is in continuous development at TI and users should exercise care to ensure any changes do not conflict with future releases. To modify the library while maintaining compatibility with future releases, the following precautions should be observed.

- Do not modify the DCL functions directly. To modify library code, first copy the code into a new function with a different name, then modify the new function. This will ensure that user code remains compatible with future library releases.
- Select a name which will not conflict with future library versions. See section 1.3.3 for a description of function naming. Controller numbers of 20 and above are reserved for customer use. For example, the TI library will never contain a function `DCL_runPI_C20`, so users are free to use that function name for their own code.
- Users are not obliged use the DCL controller structures, however they are free to do so. It is suggested that any new custom structures use a name which is prefixed differently from the library, for example, by replacing `DCL_` with `DCLU_`.

```
typedef volatile struct {  
    float32_t Kp;  
    float32_t Ki;  
    ...  
} DCLU_PID;
```

- Users need not apply the parameter update or error checking methods described in sections 2.4 and 2.5, however they are free to do so. It is intended that future library versions will be compatible with v3.4 in this respect.

---

---

# Controllers

---

---

This chapter provides detailed information on the controller functions in the Digital Control Library.

## Section

- 3.1 Linear PID Controllers**
- 3.2 Linear PI Controllers**
- 3.3 Nonlinear PID Controllers**
- 3.4 Nonlinear PI Controller**
- 3.5 Double Integrator PI Controller**
- 3.6 Direct Form 1 (first order) Compensators**
- 3.7 Direct Form 1 (third order) Compensators**
- 3.8 Direct Form 2 (second order) Compensators**
- 3.9 Direct Form 2 (third order) Compensators**
- 3.10 Fixed Point PID Controllers**
- 3.11 Fixed Point PI Controllers**
- 3.12 Gain Scheduler Module**
- 3.13 Non-linear Law**
- 3.14 Double Precision PID Controllers**

The DCL contains the following controller types:

- Linear PID
- Linear PI
- Non-linear PID
- Non-linear PI
- Double Integrator
- Direct Form 1 (first order)
- Direct Form 1 (third order)



- Direct Form 2 (second order)
- Direct Form 2 (third order)
- Gain scheduler

In this guide, the four direct form types are referred to as ‘compensators’. This reflects a situation common in power supply design, in which the design objective is to compensate some feature of the open loop frequency response, such as phase shift. The compensator is usually specified using a set of pole & zero frequencies, which leads naturally to a transfer function description. The term ‘Direct Form’ comes from transfer function descriptions of digital filters which have a similar structure.

Controllers are either coded in C, or in assembly using three different instruction sets (C28x, FPU32, and CLA). Additionally, most of the Direct Form compensators are implemented in both full and pre-computed forms. There may therefore be several different functions for each controller to allow the user to balance execution time with ease-of-tuning. Different implementations of the same controller are identified using a two character suffix to the ‘run’ function name (refer to section 1.3.2 for information on function naming).

The description of each controller in this chapter is broken down into three sub-sections:

- A general description of the controller
- Information of the implementation of the controller
- A description of functions

The ‘implementation’ sub-section always includes a block diagram showing the internal structure and the variables used in the code. Local variables, which do not need to be preserved between functions, are pre-fixed with the letter “v”. Variables which are part of the controller structure and are therefore preserved between function calls are pre-fixed with some other letter according to their purpose: for example, “i10” refers to a variable used in the PID integrator. The prefix letter “l” is reserved for logical signals. The same variable names are used in the library source code, making it straightforward to compare the controller diagrams with the source code.

It is sometimes useful to monitor internal controller variables (i.e. which are not elements in the controller structure) for debugging purposes. The CSS sub-structure contains a test-point element named “tpt” which is intended to be used for this purpose. Controller test-points are globally enabled using the following definition in `DCL.h`. Note that by default, this definition is commented out to reduce execution cycles.

```
#define DCL_TESTPOINTS_ENABLED
```

Users may un-comment the above line, and then assign any internal variable to the tpt element for monitoring, perhaps in the CCS “Expressions” window or using a data logger.

## 3.1 Linear PID Controllers

### 3.1.1 Description

The basic controller type described here is a linear PID. The PID implementations in the DCL include several features not commonly found in basic PID designs, and this complexity is reflected the benchmark figures. Applications which do not require

derivative action, or are more sensitive to cycle efficiency, may be better served by the simpler PI controller structure described in the next section.

PID control is widely used in systems which employ output feedback control. In such systems, the controlled output is measured and fed back to a summing point where it is subtracted from the reference input. The difference between the reference and feedback corresponds to the control loop error and forms the input to the PID controller.

Conceptually, the PID controller output is the parallel sum of three paths which act respectively on the error, error integral, and error derivative. The relative weight of each path may be adjusted by the user to optimize transient response, or to emulate the behavior of a specified transfer function expressed in terms of its' poles and zeros.

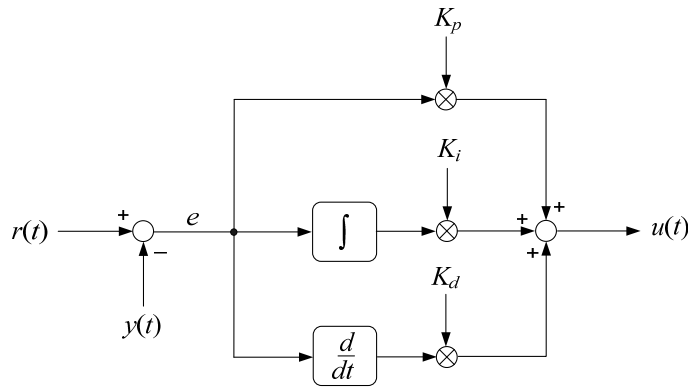

Figure 5. Parallel form PID controller

The diagram above shows the structure of a continuous time ‘parallel’ PID controller. The output of this controller is captured in the following equation:

$$\text{Equation 2. } u(t) = K_p e(t) + K_i \int_{-\infty}^t e(\tau) d\tau + K_d \frac{de(t)}{dt}$$

Conceptually, the controller comprises three separate paths connected in parallel. The upper path contains an adjustable gain term ( $K_p$ ). Its effect is to fix the open loop gain of the control system. Since loop gain is proportional to this term,  $K_p$  is known as proportional gain.

A second path contains an integrator which accumulates error history. A separate gain term acts on this path. The output of the integral path changes continuously as long as a non-zero error ( $e$ ) is present at the controller input. A small but persistent servo error has the effect of driving the output of the integrator such that the loop error will eventually disappear. The principal effect of the integral path is therefore to eliminate steady state error. The effect of the integral gain term is to change the rate at which this happens. Integral action is especially important in applications such as electronic power supplies, which must maintain accurate regulation over long periods of time.

The third path contains a differentiator. The output of this path is large whenever the rate of change of the error is large. The principal effects of the derivative action are to damp oscillation and reduce transients.

The operation of the PID controller can be visualized in terms of the transient error following a step change of set-point.

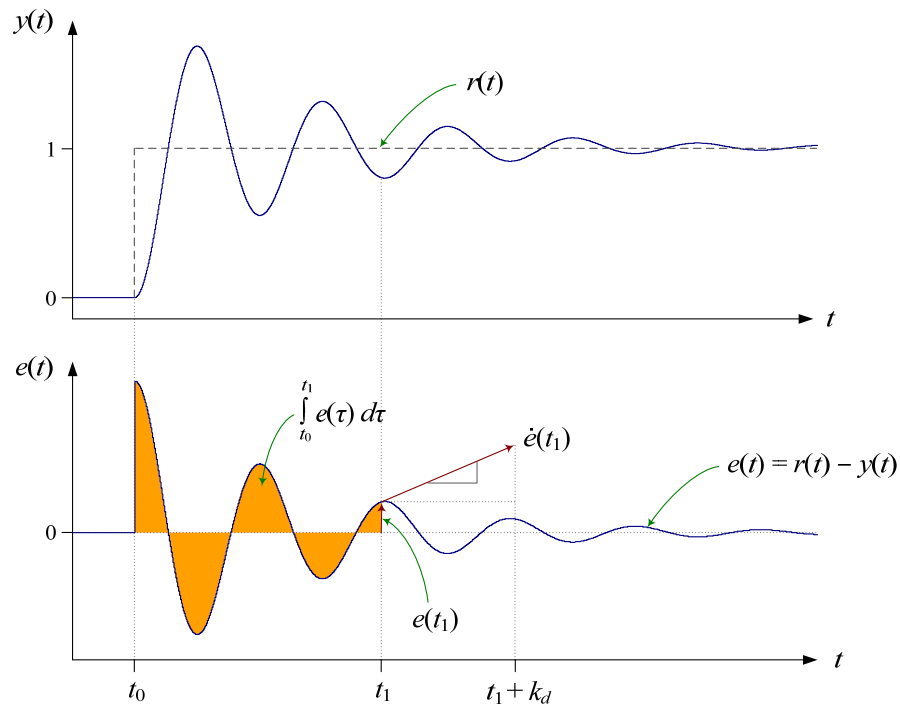

Figure 6. *PID control action*

The figure above shows the action of the PID controller in terms of the control loop error at time  $t_1$ . The proportional term contributes a control effort which is proportional to the instantaneous loop error. The output of the integral path is the accumulated error history: the shaded area in the lower plot. The contribution of the derivative path is proportional to the rate of change of the loop error. Derivative gain fixes the time interval over which a tangential line to the error curve is projected forward in time.

Tuning the PID controller is a matter of finding the optimum combination of these three effects. This in turn means finding the best balance of the three gain terms. For more information on PID control & tuning, see the references in section 6.1.

The PID shown above is known as the “parallel” form because the three controller gains appear in separate parallel paths. A slightly different PID architecture in which the proportional gain is moved into the output path (i.e. after the summing point), so that the proportional path becomes a direct connection between the controller input and the summing point, is known as the “series” or “ideal” form. In the ideal form, the open loop gain is directly influenced by the proportional controller gain, and there is less interaction between the controller gains. However the proportional gain cannot be zero (since the loop would be opened), and to maintain good control cannot be small. The parallel form allows the proportional gain to be small, however there is slightly more interaction between the controller gains, complicating the tuning process. The DCL contains both ideal and parallel PID functions.

### 3.1.2 Implementation

The linear PID controllers in the DCL include the following features:

- Parallel and ideal forms

- Programmable output saturation
- Independent reference weighting on proportional path
- Anti-windup integrator reset
- Programmable low-pass derivative filter
- External saturation input for integrator anti-windup
- Adjustable output saturation

It is important to note that the controller sample period is not accounted for in the selection of integral gain ( $K_i$ ). This is relevant when computing the integral gain as opposed to manual tuning against a transient response, for example. In such situations, users must multiply the computed integral gain by the sample period before loading  $K_i$  (either directly or through the SPS). The element  $T$  in the CSS sub-structure can be used to store the sample period for this purpose.

All PID type controllers in the library implement integrator anti-windup reset in a similar way. A clamp is present at the controller output which allows the user to set upper and lower limits on the control effort. If either limit is exceeded, an internal floating-point controller variable changes from 1.0 to 0.0. This variable is multiplied by the integrator input, such that the integrator accumulates zero data only when the output is saturated, thus preventing the well-known “wind-up” phenomenon.

The PID controllers in the library make provision for anti-windup reset to be triggered from an external part of the loop. This is useful in situations where a component outside the controller may be saturated. The floating-point variable  $lk$  is expected to be either 1.0 or 0.0 in the normal and saturated conditions respectively. If this feature is not required, the functions should be called with the  $lk$  argument set to 1.0. Note that all the controllers here require non-zero proportional gain to recover from loop saturation.

The derivative PID path includes a digital low-pass filter to avoid amplification of unwanted high frequency noise. The filter implemented here is a simple first order lag filter (with differentiator), converted into discrete form using the Tustin transform. Referring to Figure 6, the difference equation of the filtered differentiator is

$$\text{Equation 3. } v_4(k) = v_1(k) - d_2(k) - d_3(k)$$

The temporary storage elements  $d_2$  &  $d_3$  must be preserved from the  $(k - 1)^{\text{th}}$  interval, so the following must be computed after the differentiator update.

$$\text{Equation 4. } d_2(k) = v_1(k - 1)$$

$$\text{Equation 5. } d_3(k) = c_2 v_4(k - 1)$$

The derivative filter coefficients are

$$\text{Equation 6. } c_1 = \frac{2}{T + 2\tau}$$

$$\text{Equation 7. } c_2 = \frac{T - 2\tau}{T + 2\tau}$$

Both the sample period ( $T$ ) and filter time constant ( $\tau$ ) must be determined by the user. The time constant is the reciprocal of the desired filter bandwidth in radians per second.

All linear PID controller functions use a common C structure to hold coefficients and data. Refer to the header file `DCLF32.h` for details of the `DCL_PID` controller structure.

The library PID controller architectures are shown below:

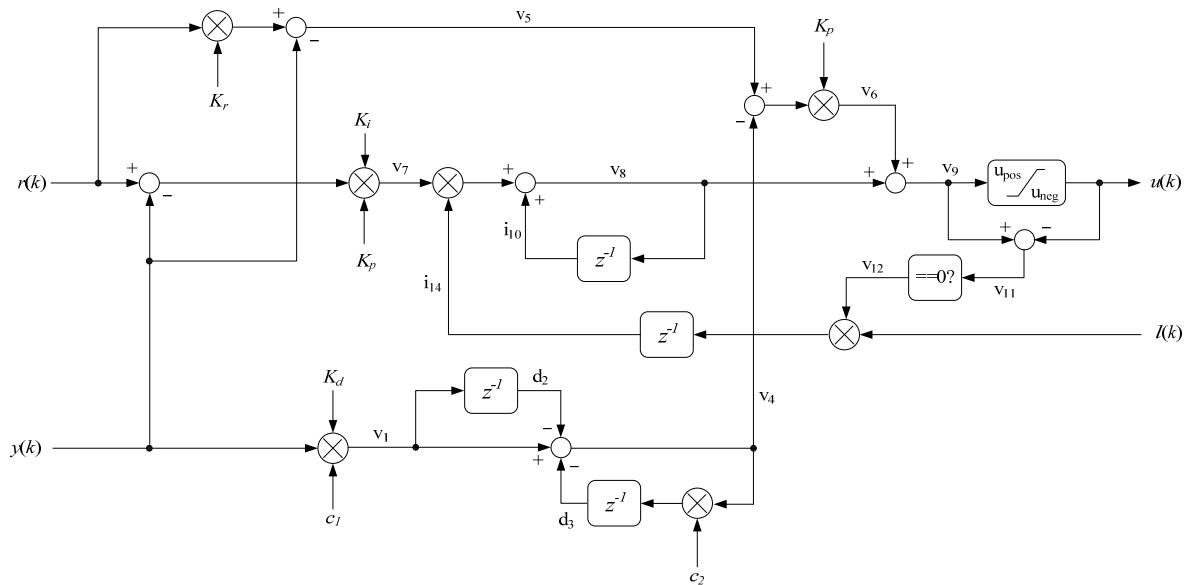

Figure 7. DCL\_PID C1, C2, & L1 architecture

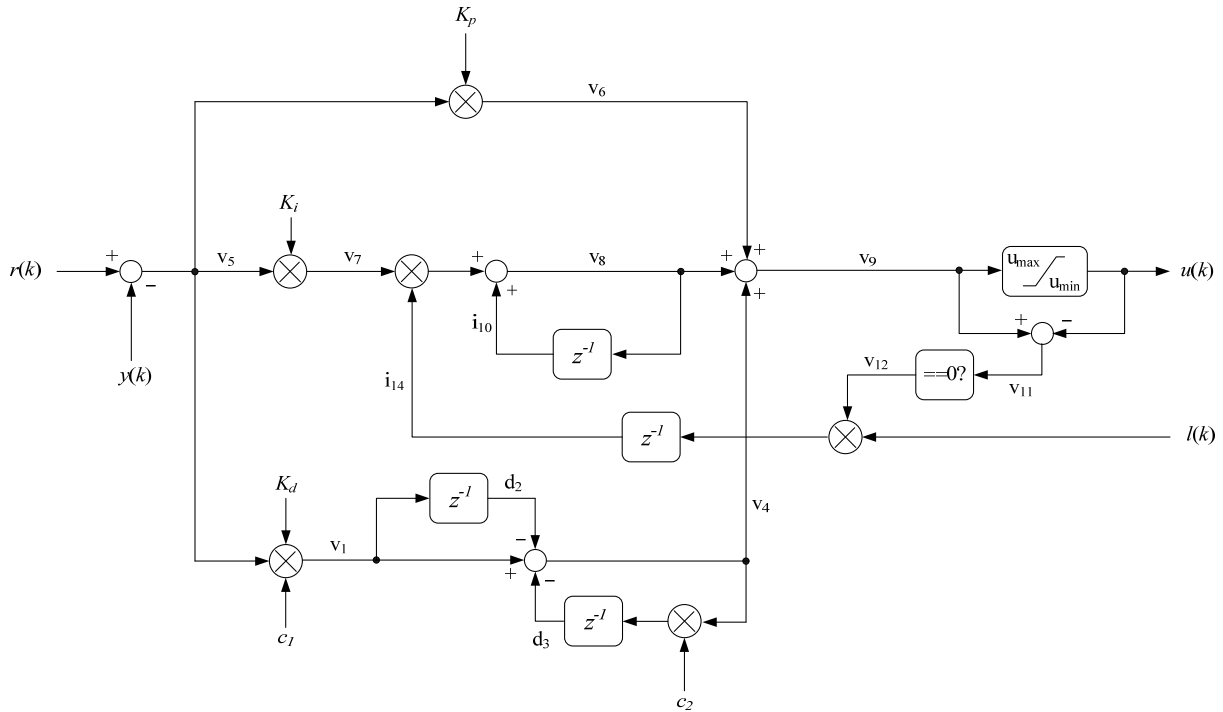

Figure 8. DCL\_PID C3, C4, & L2 architecture

### 3.1.3 Functions

<b>DCL_runPID_C1</b>	<b>Run the Ideal Form PID Controller</b>
----------------------	--

Header File: DCLF32.h

Source File: DCL\_PID\_C1.asm

Declaration: float32\_t DCL\_runPID\_C1(DCL\_PID \*p, float32\_t rk, float32\_t yk, float32\_t lk)

Description: This function executes an ideal form PID controller on the FPU32. The function is coded in assembly.

Parameters:

- p                    The DCL\_PID structure
- rk                   The controller set-point reference
- yk                   The measured feedback
- lk                   External output clamp flag

Return:              The control effort

<b>DCL_runPID_C2</b>	<b>Run the Ideal PID Form Controller</b>
----------------------	--

Header File: DCLF32.h

Source File: N/A

Declaration: float32\_t DCL\_runPID\_C2(DCL\_PID \*p, float32\_t rk, float32\_t yk, float32\_t lk)

Description: This function executes an ideal form PID controller on the FPU32, and is identical in structure and operation to the C1 form. The function is coded in inline C.

Parameters: p The DCL\_PID structure  
rk The controller set-point reference  
yk The measured feedback  
lk External output clamp flag

Return: The control effort

<b>DCL_runPID_C3</b>	<b><i>Run the Parallel Form PID Controller</i></b>
----------------------	--

Header File: DCLF32.h

Source File: N/A

Declaration: float32\_t DCL\_runPID\_C3(DCL\_PID \*p, float32\_t rk, float32\_t yk, float32\_t lk)

Description: This function executes a parallel form PID controller on the FPU32. The function is coded in inline C.

Parameters: p The DCL\_PID structure  
rk The controller set-point reference  
yk The measured feedback  
lk External output clamp flag

Return: The control effort

<b>DCL_runPID_C4</b>	<b><i>Run the Parallel Form PID Controller</i></b>
----------------------	--

Header File: DCLF32.h

Source File: DCL\_PID\_C4.asm

Declaration: float32\_t DCL\_runPID\_C4(DCL\_PID \*p, float32\_t rk, float32\_t yk, float32\_t lk)

Description: This function executes a parallel form PID controller on the FPU32, and is identical in structure and operation to the C3 form. The function is coded in inline C.

Parameters: p The DCL\_PID structure  
rk The controller set-point reference  
yk The measured feedback  
lk External output clamp flag

Return: The control effort

<b>DCL_runPID_L1</b>	<b>Run the Ideal Form PID Controller</b>
----------------------	--

Header File: DCLCLA.h

Source File: DCL\_PID\_L1.asm

Declaration: float32\_t DCL\_runPID\_L1(DCL\_PID\_CLA \*p, float32\_t rk, float32\_t yk, float32\_t lk)

Description: This function executes an ideal form PID controller on the CLA. The function is coded in CLA assembly.

Parameters:

p	The DCL_PID_CLA structure
rk	The controller set-point reference
yk	The measured feedback
lk	External output clamp flag

Return: The control effort

<b>DCL_runPID_L2</b>	<b>Run the Parallel Form PID Controller</b>
----------------------	---

Header File: DCLCLA.h

Source File: DCL\_PID\_L2.asm

Declaration: float32\_t DCL\_runPID\_L2(DCL\_PID\_CLA \*p, float32\_t rk, float32\_t yk, float32\_t lk)

Description: This function executes a parallel form PID controller on the CLA. The function is coded in CLA assembly.

Parameters:

p	The DCL_PID_CLA structure
rk	The controller set-point reference
yk	The measured feedback
lk	External output clamp flag

Return: The control effort

<b>DCL_resetPID</b>	<b>Resets the PID Controller</b>
---------------------	----------------------------------

Header File: DCLF32.h

Source File: N/A

Declaration: void DCL\_resetPID(DCL\_PID \*p)



Description: This function resets the internal variables in the `DCL_PID` structure to default values. The integrator accumulator and store derivative path values are set to 0.0, and the integrator clamp variable set to 1.0. The function also sets the `err` field in the CSS sub-structure to NONE. Note that the function is atomic.

Parameters: `p`                      The `DCL_PID` structure

Return:                      Void

<b><i>DCL_updatePID</i></b>	<b><i>Updates the PID Controller Parameters</i></b>
-----------------------------	---

Header File:    `DCLF32.h`

Source File:    `N/A`

Declaration:    `void DCL_updatePID(DCL_PID *p)`

Description:    This function tests the `sts` field in the CSS sub-structure to determine whether a parameter update is required. If so, the parameters stored in the SPS sub-structure are copied into the PID structure and `sts` is cleared. Note that the function is atomic. Refer to section 2.4 for more information on updating controller parameters.

Parameters:    `p`                      The `DCL_PID` structure

Return:                      Void

<b><i>DCL_fupdatePID</i></b>	<b><i>Updates the PID Controller Parameters</i></b>
------------------------------	---

Header File:    `DCLF32.h`

Source File:    `DCL_futils.asm`

Declaration:    `void DCL_fupdatePID(DCL_PID *p)`

Description:    This function tests the `sts` field in the CSS sub-structure to determine whether a parameter update is required. If so, the parameters stored in the SPS sub-structure are copied into the PID structure and `sts` is cleared. Note that the function is atomic. Refer to section 2.4 for more information on updating controller parameters. The function is implemented as an assembly module.

Parameters:    `p`                      The `DCL_PID` structure

Return:                      Void

<b><i>DCL_setPIDfilterBW</i></b>	<b><i>Set the PID Derivative Filter Bandwidth</i></b>
----------------------------------	---

Header File:    `DCLF32.h`

Source File:    `N/A`

Declaration:    `void DCL_setPIDfilterBW(DCL_PID *p, float32_t fc)`

Description: Loads the derivative filter coefficients  $c_1$  &  $c_2$  in the SPS based on the desired filter bandwidth specified in Hz. Coefficients in the active parameter set are unaffected until the controller is updated using `DCL_updatePID()`.

Parameters:  $p$  The DCL\_PID structure  
 $fc$  The desired filter bandwidth in Hz

Return: Void

<b>DCL_setActivePIDfilterBW</b>	<b>Set the Active PID Derivative Filter Bandwidth</b>
---------------------------------	---

Header File: DCLF32.h

Source File: N/A

Declaration: `void DCL_setActivePIDfilterBW(DCL_PID *p, float32_t fc, float32_t T)`

Description: Loads the derivative filter coefficients  $c_1$  &  $c_2$  in the active PID structure based on the desired filter bandwidth specified in Hz and the controller update date in seconds. This function does not use or modify the SPS.

Parameters:  $p$  The DCL\_PID structure  
 $fc$  The desired filter bandwidth in Hz  
 $T$  The controller update rate in seconds

Return: Void

<b>DCL_getPIDfilterBW</b>	<b>Get the PID Derivative Filter Bandwidth</b>
---------------------------	--

Header File: DCLF32.h

Source File: N/A

Declaration: `float32_t DCL_getPIDfilterBW(DCL_PID *p)`

Description: Finds the bandwidth of the current derivative filter in Hz by examining the coefficients in the active parameter set (i.e. not the SPS).

Parameters:  $p$  The DCL\_PID structure

Return: The active derivative filter bandwidth in Hz

<b>DCL_loadSeriesPIDasZPK</b>	<b>Load the Series Form PID Controller from ZPK</b>
-------------------------------	---

Header File: DCLF32.h

Source File: N/A

Declaration: `void DCL_loadSeriesPIDasZPK(DCL_PID *p, DCL_ZPK3 *q)`

**Description:** Loads the SPS coefficients to implement a series form PID controller (e.g. C1, C2 or L1) based on a ZPK3 definition. The ZPK3 is expected to be in the form of a complex zero pair, plus one real pole, plus an integrator. The real pole corresponds to the pole in the derivative path filter. Note that the active coefficients are not affected until the controller is updates using `DCL_updatePID()`. Refer to section 1.3.8 for more information on the ZPK3 structure.

**Parameters:** p                    The DCL\_PID structure  
q                                    The ZPK3 structure

**Return:**                    Void

<b>DCL_loadParallelPIDasZPK</b>	<b>Load the Parallel Form PID Controller from ZPK</b>
---------------------------------	---

**Header File:**    DCLF32.h

**Source File:**    N/A

**Declaration:**    void DCL\_loadSeriesPIDasZPK(DCL\_PID \*p, DCL\_ZPK3 \*q)

**Description:**    Loads the SPS coefficients to implement a parallel form PID controller (e.g. C3, C4 or L2) based on a ZPK3 definition. The ZPK3 is expected to be in the form of a complex zero pair, plus one real pole, plus an integrator. The real pole corresponds to the pole in the derivative path filter. Note that the active coefficients are not affected until the controller is updated using `DCL_updatePID()`. Refer to section 1.3.8 for more information on the ZPK3 structure.

**Parameters:**    p                    The DCL\_PID structure  
q                                    The ZPK3 structure

**Return:**                    Void

### 3.2 Linear PI Controllers

#### 3.2.1 Description

The continuous time parallel PI control equation is

*Equation 8.* 
$$u(t) = K_p e(t) + K_i \int_{-\infty}^t e(\tau) d\tau$$

The linear PI controllers in the DCL differ from the PID in the following respects.

- Removal of derivative path
- Removal of set-point weighting
- No provision for external saturation input

In all other respects, the PI controllers are similar to the PID controllers described in section 3.1.

### 3.2.2 Implementation

All linear PI controller functions use a common C structure to hold coefficients and data, defined in the header files `DCLF32.h` and `DCLCLA.h`.

The PI controller architectures are shown in the following diagrams.

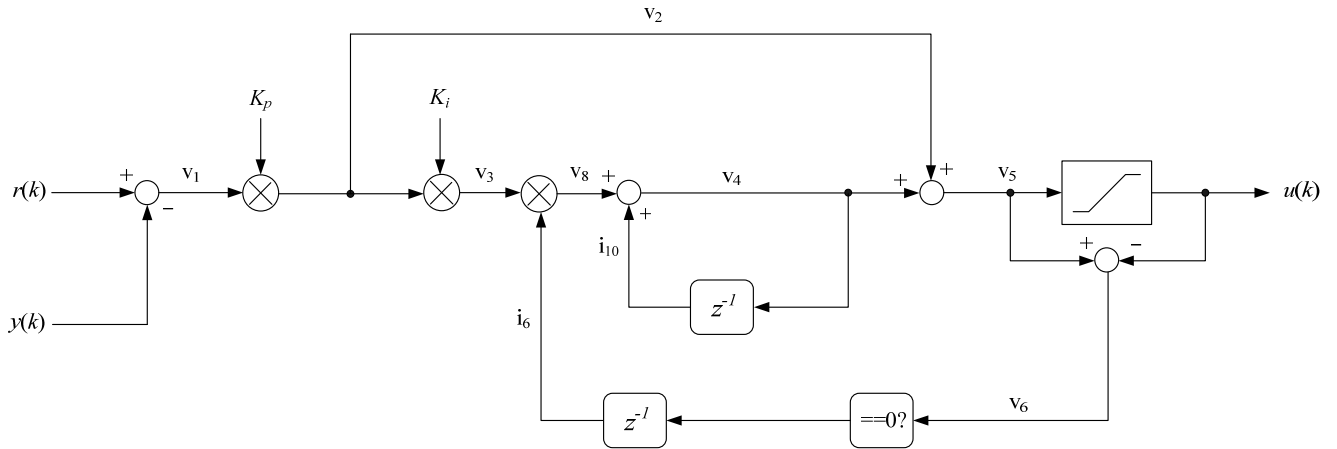

Figure 9. *DCL\_PI C1, C2, L1, & L3 architecture*

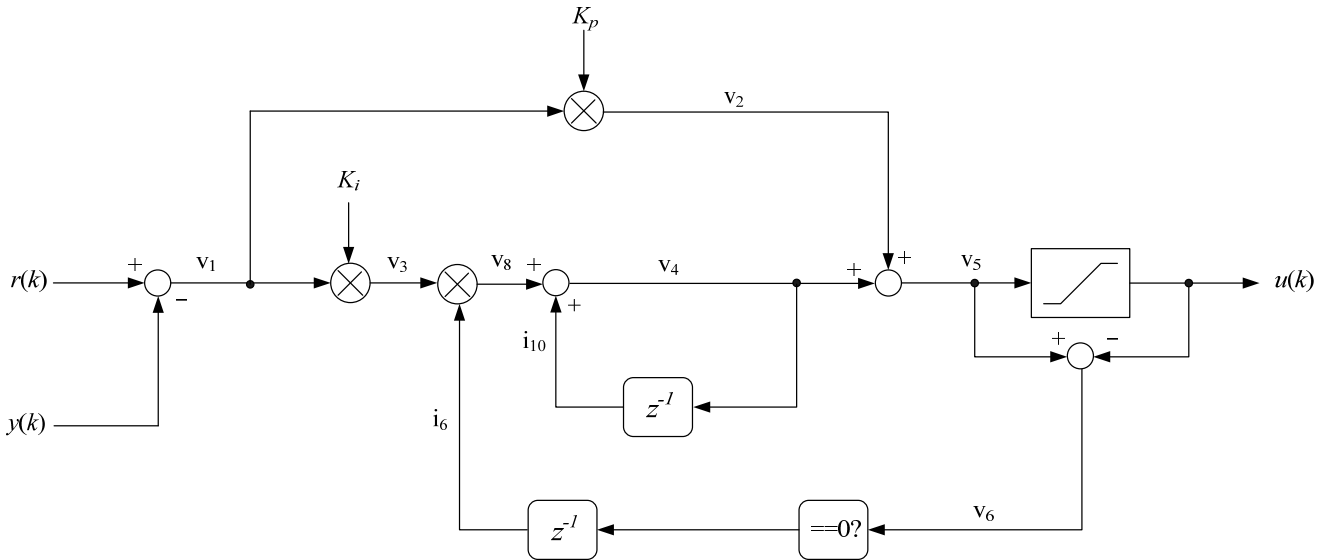

Figure 10. *DCL\_PI C3, C4, L2 & L4 architecture*

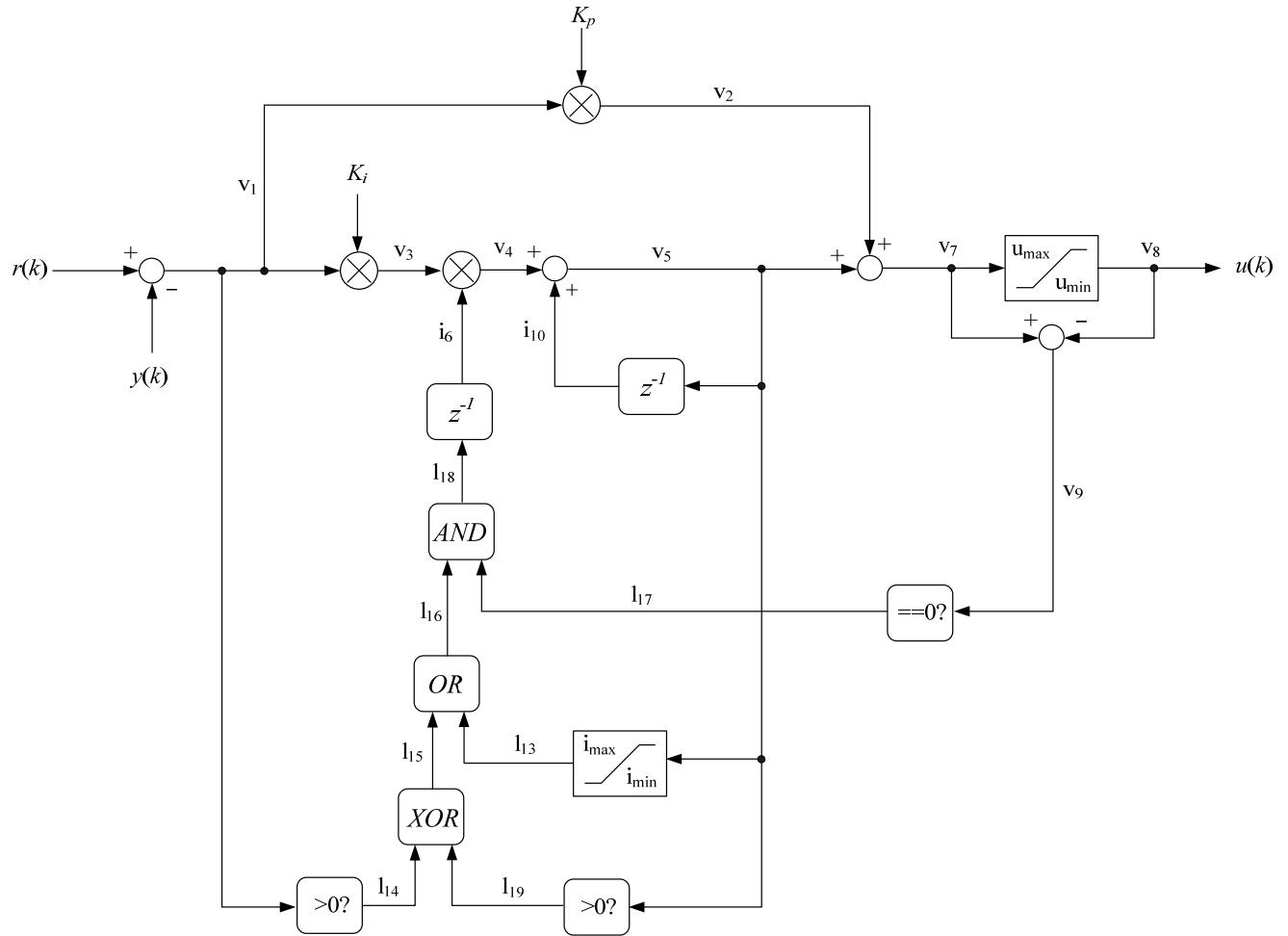

Figure 11. *DCL\_PI C5 architecture*

Note that the C5 parallel form PI controller contains enhanced anti-windup reset logic which allows the integral path to recover from saturation even when the proportional gain is zero.

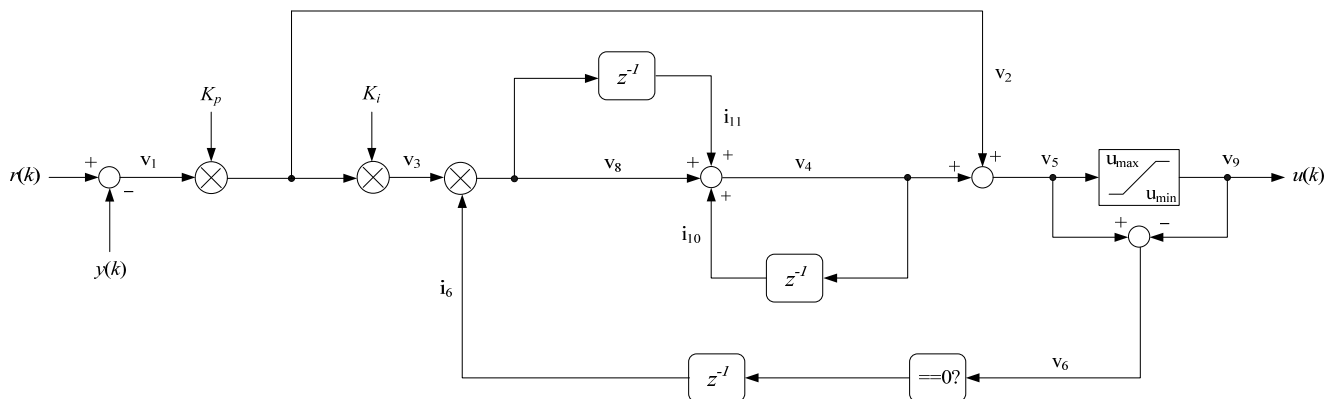

Figure 12. *DCL\_PI C6, C7, & L5 architecture*

The C6, C7, & L5 controllers combine a series form PI with a Tustin integrator. This configuration is best suited to applications in which the controller gains are selected on the basis of high frequency loop gain and zero frequency, because Kp and Ki are effectively un-coupled in the series form controller. Furthermore the Tustin integrator has fixed 90 degree phase lag at all frequencies below the Nyquist limit, simplifying design of the compensator.

### 3.2.3 Functions

<b>DCL_runPI_C1</b>	<b>Run the Ideal Form PI Controller</b>
---------------------	---

Header File: DCLF32.h

Source File: DCL\_PI\_C1.asm

Declaration: float32\_t DCL\_runPI\_C1(DCL\_PI \*p, float32\_t rk, float32\_t yk)

Description: This function executes an ideal form PI controller on the FPU32. The function is coded in assembly.

Parameters:

p	The DCL_PI structure
rk	The controller set-point reference
yk	The measured feedback

Return: The control effort

<b>DCL_runPI_C2</b>	<b>Run the Ideal PI Form Controller</b>
---------------------	---

Header File: DCLF32.h

Source File: N/A

Declaration: float32\_t DCL\_runPI\_C2(DCL\_PI \*p, float32\_t rk, float32\_t yk)

Description: This function executes an ideal form PI controller on the FPU32, and is identical in structure and operation to the C1 form. The function is coded in inline C.

Parameters:

p	The DCL_PI structure
rk	The controller set-point reference
yk	The measured feedback

Return: The control effort

<b>DCL_runPI_C3</b>	<b>Run the Parallel Form PI Controller</b>
---------------------	--

Header File: DCLF32.h

Source File: N/A

Declaration: float32\_t DCL\_runPI\_C3(DCL\_PI \*p, float32\_t rk, float32\_t yk)

Description: This function executes a parallel form PI controller on the FPU32. The function is coded in inline C.

Parameters: p                    The DCL\_PI structure  
rk                                The controller set-point reference  
yk                                The measured feedback

Return:                        The control effort

<b><i>DCL_runPI_C4</i></b>	<b><i>Run the Parallel Form PI Controller</i></b>
----------------------------	---

Header File:    DCLF32.h

Source File:    DCL\_PI\_C4.asm

Declaration:    float32\_t DCL\_runPI\_C4(DCL\_PI \*p, float32\_t rk, float32\_t yk)

Description:    This function executes a parallel form PI controller on the FPU32, and is identical in structure and operation to the C3 form. The function is coded in inline C.

Parameters:    p                    The DCL\_PI structure  
rk                                The controller set-point reference  
yk                                The measured feedback

Return:                        The control effort

<b><i>DCL_runPI_C5</i></b>	<b><i>Run the Parallel Form PI Controller</i></b>
----------------------------	---

Header File:    DCLF32.h

Source File:    DCL\_PI\_C5.asm

Declaration:    float32\_t DCL\_runPI\_C5(DCL\_PI \*p, float32\_t rk, float32\_t yk)

Description:    This function executes a parallel form PI controller on the FPU32. The configuration includes enhanced anti-windup reset logic which produces faster recovery from integral path saturation. Note that this controller cycle count is a little higher than C4. The function is coded in inline C.

Parameters:    p                    The DCL\_PI structure  
rk                                The controller set-point reference  
yk                                The measured feedback

Return:                        The control effort

**DCL\_runPI\_C6**

**Run the Series Form PI Controller**

Header File: DCLF32.h

Source File: N/A

Declaration: float32\_t DCL\_runPI\_C6(DCL\_PI \*p, float32\_t rk, float32\_t yk)

Description: This function executes a series form PI controller with Tustin integrator on the FPU32. The function is coded in inline C.

Parameters: p                    The DCL\_PI structure  
rk                                The controller set-point reference  
yk                                The measured feedback

Return:                         The control effort

**DCL\_runPI\_C7**

**Run the Series Form PI Controller**

Header File: DCLF32.h

Source File: DCL\_PI\_C7.asm

Declaration: float32\_t DCL\_runPI\_C7(DCL\_PI \*p, float32\_t rk, float32\_t yk)

Description: This function executes a series form PI controller with Tustin integrator on the FPU32. The function is implemented in an external assembly module.

Parameters: p                    The DCL\_PI structure  
rk                                The controller set-point reference  
yk                                The measured feedback

Return:                         The control effort

**DCL\_runPI\_L1**

**Run the Ideal Form PI Controller**

Header File: DCLCLA.h

Source File: DCL\_PI\_L1.asm

Declaration: float32\_t DCL\_runPI\_L1(DCL\_PI\_CLA \*p, float32\_t rk, float32\_t yk)

Description: This function executes an ideal form PI controller on the CLA. The function is coded in CLA assembly.

Parameters: p                    The DCL\_PI\_CLA structure  
rk                                The controller set-point reference  
yk                                The measured feedback



Return: The control effort

<b><i>DCL_runPI_L2</i></b>	<b><i>Run the Parallel Form PI Controller</i></b>
----------------------------	---

Header File: DCLCLA.h

Source File: DCL\_PI\_L2.asm

Declaration: float32\_t DCL\_runPI\_L2(DCL\_PI\_CLA \*p, float32\_t rk, float32\_t yk)

Description: This function executes a parallel form PI controller on the CLA. The function is coded in CLA assembly.

Parameters: p                    The DCL\_PI\_CLA structure  
rk                            The controller set-point reference  
yk                            The measured feedback

Return: The control effort

<b><i>DCL_runPI_L3</i></b>	<b><i>Run the Ideal Form PI Controller</i></b>
----------------------------	--

Header File: DCLCLA.h

Source File: N/A

Declaration: float32\_t DCL\_runPI\_L3(DCL\_PI\_CLA \*p, float32\_t rk, float32\_t yk)

Description: This function executes an ideal form PI controller on the CLA. The function is coded in C.

Parameters: p                    The DCL\_PI\_CLA structure  
rk                            The controller set-point reference  
yk                            The measured feedback

Return: The control effort

<b><i>DCL_runPI_L4</i></b>	<b><i>Run the Parallel Form PI Controller</i></b>
----------------------------	---

Header File: DCLCLA.h

Source File: N/A

Declaration: float32\_t DCL\_runPI\_L4(DCL\_PI\_CLA \*p, float32\_t rk, float32\_t yk)

Description: This function executes a parallel form PI controller on the CLA. The function is coded in C.

Parameters: p                    The DCL\_PI\_CLA structure  
rk                            The controller set-point reference

Return:           yk                   The measured feedback  
                   The control effort

<b><i>DCL_runPI_L5</i></b>	<b><i>Run the Series Form PI Controller</i></b>
----------------------------	---

Header File:   DCLCLA.h  
 Source File:   N/A  
 Declaration:   float32\_t DCL\_runPI\_L5(DCL\_PI\_CLA \*p, float32\_t rk, float32\_t yk)  
 Description:   This function executes a series form PI controller with Tustin integrator on the CLA. The function is coded in inline C.  
 Parameters:    p                   The DCL\_PI\_CLA structure  
                  rk                  The controller set-point reference  
                  yk                  The measured feedback  
 Return:        The control effort

<b><i>DCL_resetPI</i></b>	<b><i>Resets the PI Controller</i></b>
---------------------------	--

Header File:   DCLF32.h  
 Source File:   N/A  
 Declaration:   void DCL\_resetPI(DCL\_PI \*p)  
 Description:   This function resets the internal variables in the DCL\_PI structure to default values. The integrator accumulator is set to zero, and the `err` field in the CSS sub-structure is set NONE. Note that the function is atomic.  
 Parameters:    p                   The DCL\_PI structure  
 Return:        Void

<b><i>DCL_updatePI</i></b>	<b><i>Updates the PI Controller Parameters</i></b>
----------------------------	--

Header File:   DCLF32.h  
 Source File:   N/A  
 Declaration:   void DCL\_updatePI(DCL\_PI \*p)  
 Description:   This function tests the `sts` field in the CSS sub-structure to determine whether a parameter update is required. If so, the parameters stored in the SPS sub-structure are copied into the PI structure and `sts` is cleared. Note that the function is atomic. Refer to section 2.4 for more information on updating controller parameters.

Parameters: p                    The DCL\_PI structure  
 Return:            Void

<b><i>DCL_fupdatePI</i></b>	<b><i>Updates the PI Controller Parameters</i></b>
-----------------------------	--

Header File:    DCLF32.h  
 Source File:    DCL\_futils.asm  
 Declaration:    void DCL\_fupdatePI(DCL\_PI \*p)  
 Description:    This function tests the `sts` field in the CSS sub-structure to determine whether a parameter update is required. If so, the parameters stored in the SPS sub-structure are copied into the PI structure and `sts` is cleared. Note that the function is atomic. Refer to section 2.4 for more information on updating controller parameters. The function is implemented as an assembly module.  
 Parameters:    p                    The DCL\_PI structure  
 Return:            Void

<b><i>DCL_loadSeriesPlasZPK</i></b>	<b><i>Load the Series Form PI Controller from ZPK</i></b>
-------------------------------------	---

Header File:    DCLF32.h  
 Source File:    N/A  
 Declaration:    void DCL\_loadSeriesPlasZPK(DCL\_PI \*p, DCL\_ZPK3 \*q)  
 Description:    Loads the SPS coefficients to implement a series form PI controller (e.g. C1, C2 or L1) based on a ZPK3 definition (one real zero plus integrator). Note that the active coefficients are not affected until the controller is updates using `DCL_updatePI()`. Refer to section 1.3.8 for more information on the ZPK3 structure.  
 Parameters:    p                    The DCL\_PI structure  
                   q                    The ZPK3 structure  
 Return:            Void

<b><i>DCL_loadParallelPlasZPK</i></b>	<b><i>Load the Parallel Form PI Controller from ZPK</i></b>
---------------------------------------	---

Header File:    DCLF32.h  
 Source File:    N/A  
 Declaration:    void DCL\_loadSeriesPlasZPK(DCL\_PI \*p, DCL\_ZPK3 \*q)  
 Description:    Loads the SPS coefficients to implement a parallel form PI controller (e.g. C3, C4, C5, or L2) based on a ZPK3 definition (one real zero plus integrator). Note that

the active coefficients are not affected until the controller is updated using `DCL_updatePI()`. Refer to section 1.3.8 for more information on the ZPK3 structure.

Parameters: p            The DCL\_PI structure  
               q            The ZPK3 structure  
 Return:        Void

### 3.3 Non-linear PID Controller

#### 3.3.1 Description

The DCL includes two implementations of a non-linear PID controller, denoted NLPID. The controllers are broadly similar to the ideal PID\_C1 controller, except that there is no set-point weighting and in one case the derivative path sees the servo error instead of the feedback. A non-linear gain block appears in series with each of the three paths.

To improve computational efficiency, the non-linear law is separated into two parts: one part which is common to all paths, and a second part which contains terms specific to each path. The non-linear part of the high-level controller structure is shown below:

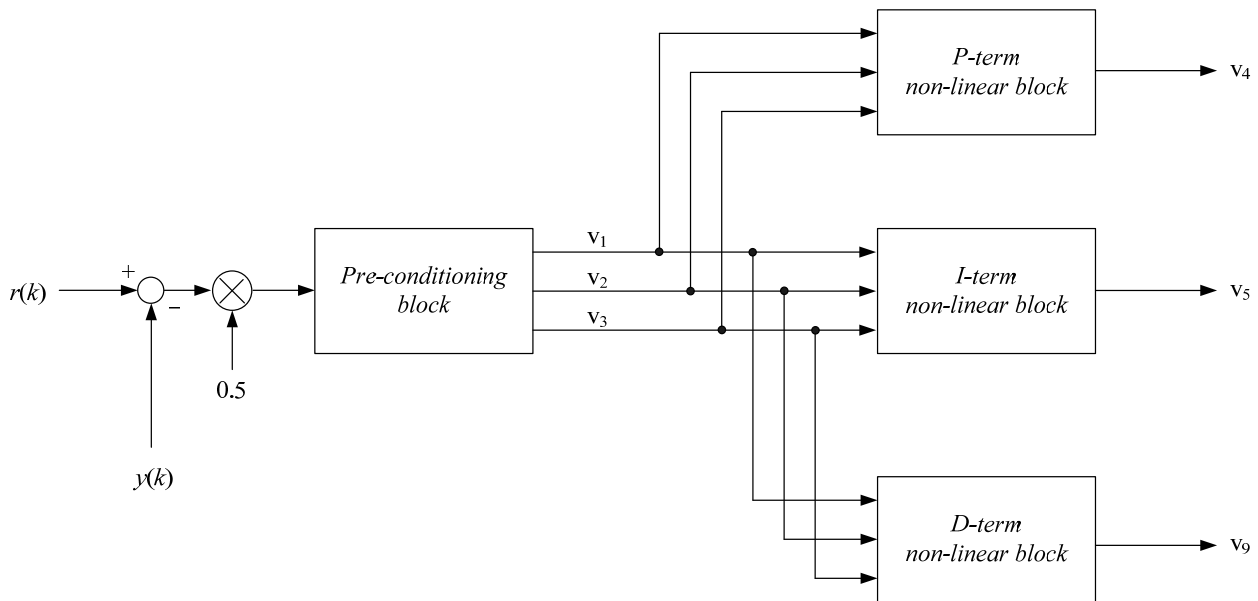

Figure 13. *DCL\_NLPID C1 input architecture*

The linear part of the DCL\_NLPID\_C1 controller is shown below:

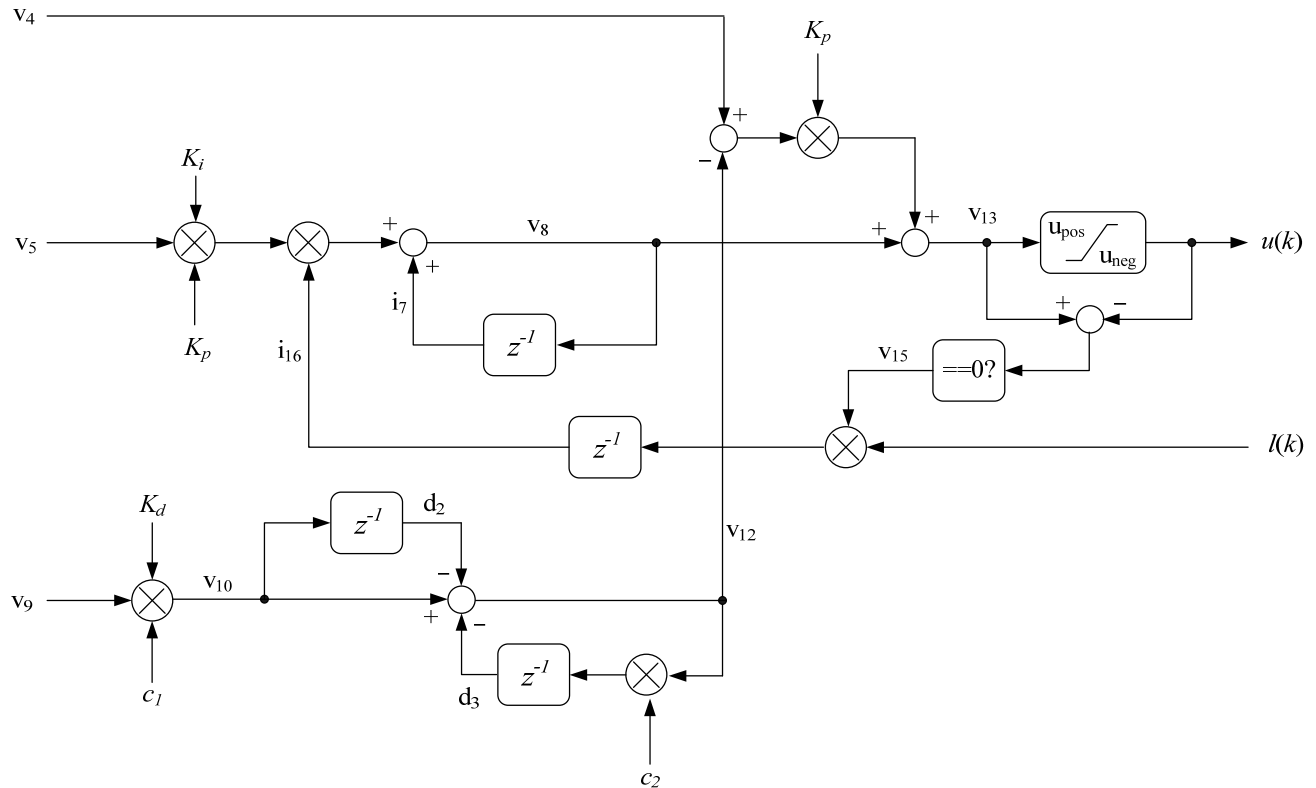

Figure 14. DCL\_NLPID C1 output architecture

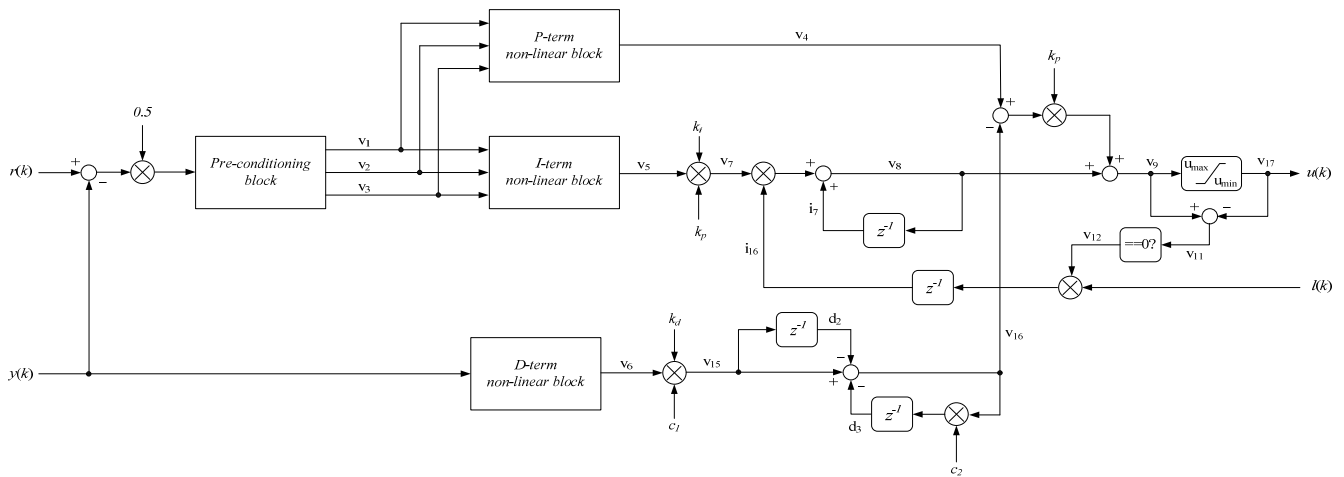

Figure 15. DCL\_NLPID C2 & C3 architecture

The non-linear control law is based on a power function of the modulus of the servo error, with a linearized region about the zero error point. In the equation below,  $x$  represents the input to the control law,  $y$ , the output, and  $\alpha$  is a user selectable exponent representing the degree of non-linearity.

Equation 9.  $y = |x|^\alpha \text{sign}(x)$

The following plot shows the x-y relationship for values of  $\alpha$  between 0.2 and 2. Notice that the curves intersect at  $x = 0$ , and  $x = \pm 1$ .

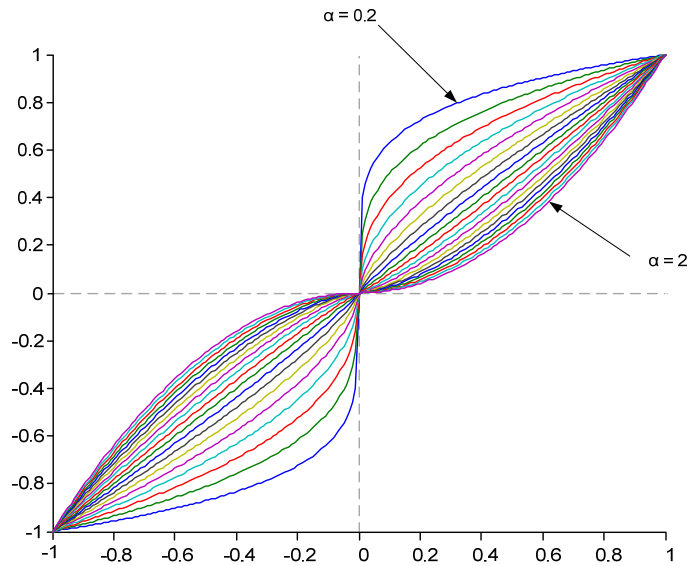

Figure 16.

*Non-linear control law input-output plot*

The gain of the control law is the slope of the x-y curve. Observe that with  $\alpha = 1$  the control is linear with unity gain. With  $\alpha > 1$  the gain is zero when  $x = 0$ , and increases as  $x$  increases. In the controller, a value of  $\alpha$  in this range produces controller gain which increases with increasing control error. With  $0 < \alpha < 1$  the gain at  $x = 0$  is infinite, and falls as  $x$  increases. This range of  $\alpha$  setting produces controller gain which decreases with increasing servo error.

The plots below show the gain vs. control loop error curves for different values of  $\alpha$ . Notice particularly the singularity at  $x = 0$  when  $\alpha < 1$ .

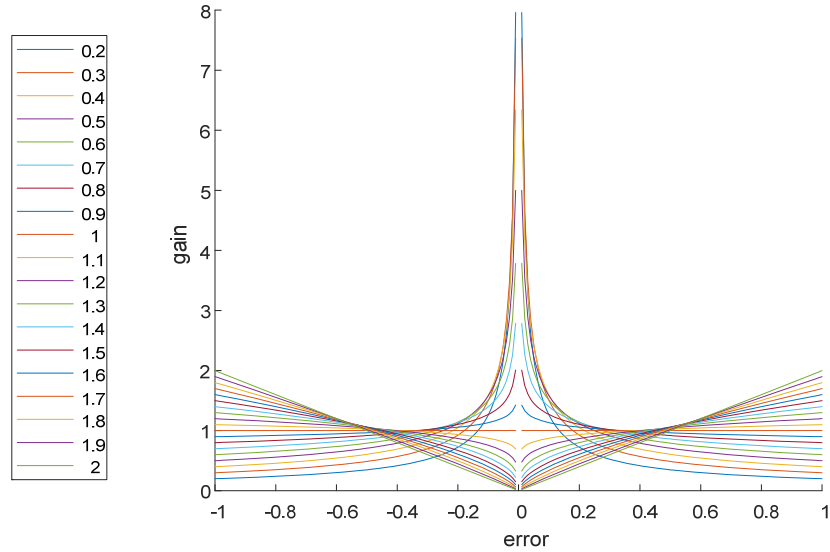

Figure 17. Gain vs error curves for varying alpha

The presence of zero or infinite gain at the zero control error point leads to practical difficulties. With  $\alpha > 1$  the response becomes sluggish for small errors; with  $\alpha < 1$  it is common to encounter oscillation or “chattering” near steady-state. These issues can be overcome by limiting the controller gain in a region close to  $x = 0$ . This is done by modifying the control law to introduce a user selectable region about  $x = 0$  with linear gain is applied. The non-linear control law becomes

$$\text{Equation 10. } y = \begin{cases} |x|^\alpha \text{sign}(x) & : |x| \geq \delta \\ x\delta^{\alpha-1} & : |x| \leq \delta \end{cases}$$

When the magnitude of servo error falls below  $\delta$  the linear gain is applied, otherwise the gain is determined by the non-linear law. For computational efficiency, we pre-compute the gain in the linear region ( $\gamma$ ) as follows.

$$\text{Equation 11. } \gamma = \delta^{\alpha-1}$$

A typical plot of the linearized control law is shown below. Observe that when  $x = \delta$  the linear and non-linear curves intersect, so the controller makes a smooth transition between the linear and non-linear regions as the servo error passes through  $x = \pm\delta$ .

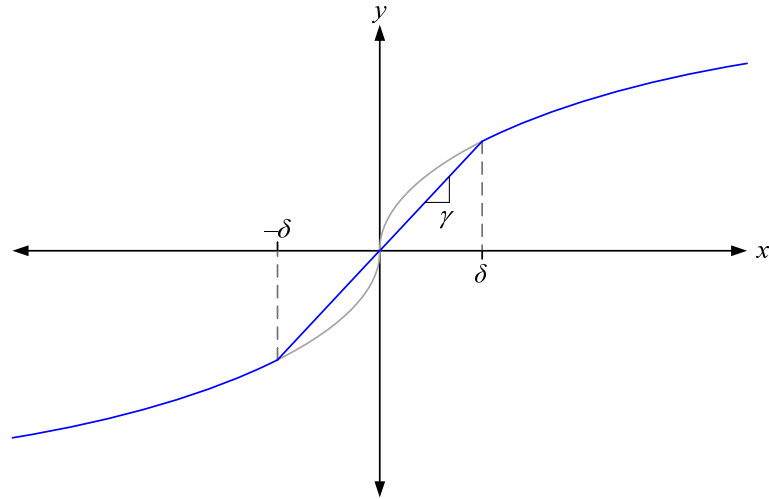

Figure 18. *NLPID linearized region*

In addition to the P, I, and D gains, the user must select two additional terms in each control path:  $\alpha$  and  $\delta$ . The library includes a separate function to compute and update  $\gamma$  for each path using the SPS structure. The user must initialize  $\gamma$  parameters before calling the NL controllers.

The NLPID controller has been seen to provide significantly improved control in many cases, however it must be remembered that increased gain, even if only applied to part of the control range, can lead to significantly increased output from the controller. In most cases, this ‘control effort’ is limited by practical factors such as actuator saturation, PWM modulation range, and so on. The corollary is that not every application benefits equally from the use of non-linear control and some may see no benefit at all. In cases where satisfactory performance cannot be achieved through the use of linear PID control, the user is advised to start with all  $\alpha = 1$ , and experiment by introducing non-linear terms gradually while monitoring both control performance and the magnitude of the control effort. In general, P and I paths benefit from increased gain at high servo error ( $\alpha > 1$ ), while the D path benefits from reduced gain at high servo error ( $\alpha < 1$ ), but this is not universally true. Further information on tuning the nonlinear PID controller can be found in the *Nonlinear PID Controller Tuning Guide* in the \docs directory of the DCL.

Further information on this control law can be found in: “*From PID to Active Disturbance Rejection Control*”, Jingqing Han, IEEE TRANSACTIONS ON INDUSTRIAL ELECTRONICS, VOL. 56, NO. 3, MARCH 2009

### 3.3.2 Implementation

The NLPID controller uses a C structure to hold coefficients and data, defined in the header file `DCL_NLPID.h`. Note that the NLPID functions make use of the `pow()` function in the standard C library. For this reason the header file `math.h` must be included, which is not supported by the CLA compiler. To allow different DCL functions to be run on both the CPU and CLA in the same program, the NLPID functions are located in a separate header file. Refer to the file `DCL_NLPID.h` for details of the NLPID controller structure.

As with all DCL controllers, it is the responsibility of the user to initialize the `DCL_NLPID` structure before use. A set of default values is defined in the library header file and can



be used with the variable declaration. An example of an initialized DCL\_NLPID structure declaration is shown below.

```
DCL_NLPID myCtrl = NLPID_DEFAULTS;
```

### 3.3.3 Functions

<b>DCL_runNLPID_C1</b>	<b>Run the Non-linear PID Controller</b>
------------------------	--

Header File: DCL\_NLPID.h

Source File: N/A

Declaration: float32\_t DCL\_runNLPID\_C1(DCL\_NLPID \*p, float32\_t rk, float32\_t yk, float32\_t lk)

Description: This function executes a parallel form non-linear PID controller on the FPU32. The function is coded in inline C.

Parameters:

p	The DCL_NLPID structure
rk	The controller set-point reference
yk	The measured feedback
lk	External output clamp flag

Return: The control effort

<b>DCL_runNLPID_C2</b>	<b>Run the Non-linear PID Controller</b>
------------------------	--

Header File: DCL\_NLPID.h

Source File: N/A

Declaration: float32\_t DCL\_runNLPID\_C2(DCL\_NLPID \*p, float32\_t rk, float32\_t yk, float32\_t lk)

Description: This function executes a series form non-linear PID controller on the FPU32. This controller is broadly similar to C1 except that the derivative path feedback comes from the loop output rather than the error. The function is coded in inline C.

Parameters:

p	The DCL_NLPID structure
rk	The controller set-point reference
yk	The measured feedback
lk	External output clamp flag

Return: The control effort

**DCL\_runNLPID\_C3**

**Run the Non-linear PID Controller**

Header File: DCL\_NLPID.h

Source File: DCL\_NLPID\_C3.asm

Declaration: float32\_t DCL\_runNLPID\_C3(DCL\_NLPID \*p, float32\_t rk, float32\_t yk, float32\_t lk)

Description: This function executes a series form non-linear PID controller on the FPU32. This controller is similar to C2 except that it is coded in assembly for the TMU type 1. If executed on a device without TMU type 1, the function will return the input reference, rk.

Parameters: p The DCL\_NLPID structure  
rk The controller set-point reference  
yk The measured feedback  
lk External output clamp flag

Return: The control effort

**DCL\_setActiveNLPIDGamma**

**Compute the Non-linear PID Gain Limits**

Header File: DCL\_NLPID.h

Source File: N/A

Declaration: void DCL\_setGamma(DCL\_NLPID \*p)

Description: This function computes the three gain limits for the non-linear PID controller and loads them directly into the active NLPID structure. The function is coded in C.

Parameters: p The DCL\_NLPID structure

Return: Void

**DCL\_setNLPIDGamma**

**Compute the Non-linear PID Gain Limits**

Header File: DCL\_NLPID.h

Source File: N/A

Declaration: void DCL\_setGamma(DCL\_NLPID \*p)

Description: This function computes the three gain limits for the non-linear PID controller and loads them into the SPS sub-structure. Parameters in the active structure are updated on the next call to DCL\_updateNLPID(). The function is coded in C.

Parameters: p                    The DCL\_NLPID structure  
 Return:                    Void

**DCL\_resetNLPID****Reset the NLPID Controller**

Header File:    DCL\_NLPID.h  
 Source File:    N/A  
 Declaration:    void DCL\_resetNLPID(DCL\_NLPID \*p)  
 Description:    This function resets the internal variables in the DCL\_NLPID structure to default values. The integrator accumulator and store derivative path values are set to 0.0, and the integrator clamp variable set to 1.0. The function also sets the `err` field in the CSS sub-structure to NONE. Note that the function is atomic.  
 Parameters:    p                    The DCL\_NLPID structure  
 Return:                    Void

**DCL\_updateNLPID****Update the NLPID Controller Parameters**

Header File:    DCL\_NLPID.h  
 Source File:    N/A  
 Declaration:    void DCL\_updateNLPID(DCL\_NLPID \*p)  
 Description:    This function tests the `sts` field in the CSS sub-structure to determine whether a parameter update is required. If so, the parameters stored in the SPS sub-structure are copied into the PID structure and `sts` is cleared. Note that the function is atomic. Refer to section 2.4 for more information on updating controller parameters.  
 Parameters:    p                    The DCL\_NLPID structure  
 Return:                    Void

**DCL\_setActiveNLPIDfilterBW****Set the Active NLPID Derivative Filter Bandwidth**

Header File:    DCL\_NLPID.h  
 Source File:    N/A  
 Declaration:    void DCL\_setActiveNLPIDfilterBW(DCL\_NLPID \*p, float32\_t fc, float32\_t T)  
 Description:    Loads the active derivative filter coefficients `c1` & `c2` in the NLPID structure based on the desired filter bandwidth specified in Hz and controller update rate in seconds. Coefficients in the SPS and CSS are unaffected.

Parameters: p            The DCL\_NLPID structure  
               fc            The desired filter bandwidth in Hz  
               T            The controller update rate in seconds

Return:        Void

<b>DCL_setNLPIDfilterBW</b>	<b>Set the NLPID Derivative Filter Bandwidth</b>
-----------------------------	--

Header File:    DCL\_NLPID.h

Source File:    N/A

Declaration:    void DCL\_setNLPIDfilterBW(DCL\_NLPID \*p, float32\_t fc)

Description:    Loads the derivative filter coefficients  $c_1$  &  $c_2$  in the SPS based on the desired filter bandwidth specified in Hz. Coefficients in the active parameter set are unaffected until the controller is updated using DCL\_updateNLPID().

Parameters:    p            The DCL\_NLPID structure  
                   fc            The desired filter bandwidth in Hz

Return:        Void

<b>DCL_getNLPIDfilterBW</b>	<b>Get the NLPID Derivative Filter Bandwidth</b>
-----------------------------	--

Header File:    DCL\_NLPID.h

Source File:    N/A

Declaration:    float32\_t DCL\_getNLPIDfilterBW(DCL\_NLPID \*p)

Description:    Finds the bandwidth of the current derivative filter in Hz by examining the coefficients in the active parameter set (i.e. not the SPS).

Parameters:    p            The DCL\_NLPID structure

Return:        The active derivative filter bandwidth in Hz

<b>DCL_getNLPIDgamma</b>	<b>Get the NLPID Steady State Gain</b>
--------------------------	--

Header File:    DCL\_NLPID.h

Source File:    N/A

Declaration:    float32\_t DCL\_getNLPIDgamma(float32\_t alpha, float32\_t delta)

Description:    Finds the steady state gain in the linearized region for the specified alpha & delta choice.

Parameters:    p            The DCL\_NLPID structure

Return: The steady state gain

**DCL\_getNLPIDdelta** **Get the NLPID Linearized Region Semi-width**

Header File: DCL\_NLPID.h

Source File: N/A

Declaration: float32\_t DCL\_getNLPIDdelta(float32\_t alpha, float32\_t gamma)

Description: Finds the semi-width of the linearized region from the specified alpha and gamma choice.

Parameters: p The DCL\_NLPID structure

Return: The linearized region semi-width

### 3.4 Non-linear PI Controllers

#### 3.4.1 Description

The DCL contains one non-linear PI controller, similar in form to DCL\_PI\_C1. Refer to section 3.3.1 for information on the non-linear control law.

#### 3.4.2 Implementation

The NLPI controller is similar to a linear series form implementation, but with non-linear law blocks in the P and I paths. The controller uses a common C structure to hold coefficients and data, defined in the header files DCL\_NLPID.h and DCL.h. The NLPI\_C1 controller architecture is shown below.

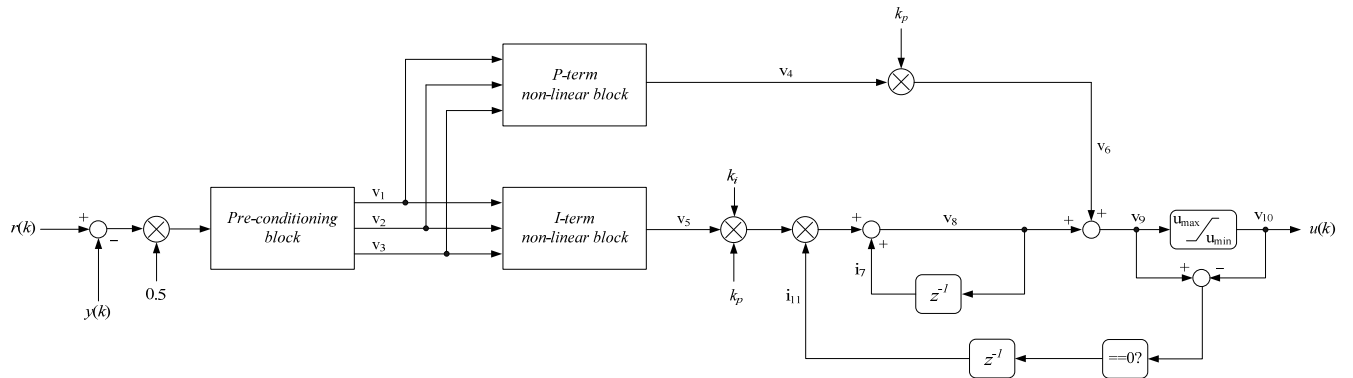

Figure 19. The DCL\_NLPI\_C1 architecture

### 3.4.3 Functions

#### **DCL\_runNLPI\_C1**

#### **Run the Ideal Form Non-linear PI Controller**

Header File: DCL\_NLPID.h

Source File: N/A

Declaration: float32\_t DCL\_runNLPI\_C1(DCL\_NLPI \*p, float32\_t rk, float32\_t yk)

Description: This function executes an ideal form PI controller on the FPU32. The function is coded in inline C.

Parameters: p                    The DCL\_NLPI structure  
rk                                The controller set-point reference  
yk                                The measured feedback

Return:                        The control effort

#### **DCL\_resetNLPI**

#### **Reset the Non-linear PI Controller**

Header File: DCL\_NLPID.h

Source File: N/A

Declaration: void DCL\_resetNLPI(DCL\_NLPI \*p)

Description: This function resets the internal dynamic variables in the DCL\_NLPI structure to their default values. The integrator accumulator is set to zero, and the `err` field in the CSS sub-structure is set NONE. Note that this function is atomic.

Parameters: p                    The DCL\_NLPI structure

Return:                        Void

#### **DCL\_updateNLPI**

#### **Update the Non-linear PI Controller Parameters**

Header File: DCL\_NLPID.h

Source File: N/A

Declaration: void DCL\_updateNLPI(DCL\_NLPI \*p)

Description: This function tests the `sts` field in the CSS sub-structure to determine whether a parameter update is required. If so, the control parameters stored in the SPS sub-structure are copied into the DCL\_NLPI structure and `sts` is cleared. Dynamic variables are not affected. Note that this function is atomic. Refer to section 2.4 for more information on updating controller parameters.

Parameters: p                    The DCL\_NLPI structure

Return:                        Void

### 3.5 Double Integrator PI Controller

#### 3.5.1 Description

The DCL contains one implementation of a linear PI controller having two series integrators. This type of controller is similar to the parallel PI controller described above except that the anti-windup reset logic is more complicated.

In this controller, allowance has been made for the  $K_p$  element to be zero. This scenario presents a problem if the controller enters saturation because without the proportional path there is no way to recover. The PI2 resolves this by releasing the anti-windup lock when the integrator input reverses sign. The logic has to be implemented twice, since there are two cascaded integrators. Similar anti-windup reset logic is present in the PI\_C5 controller (see section 3.2 for more information).

#### 3.5.2 Implementation

The double integrator PI2 controller uses a C structure to hold coefficients and data, defined in the header file `DCLF32.h`.

The PI2 implementation is shown below:

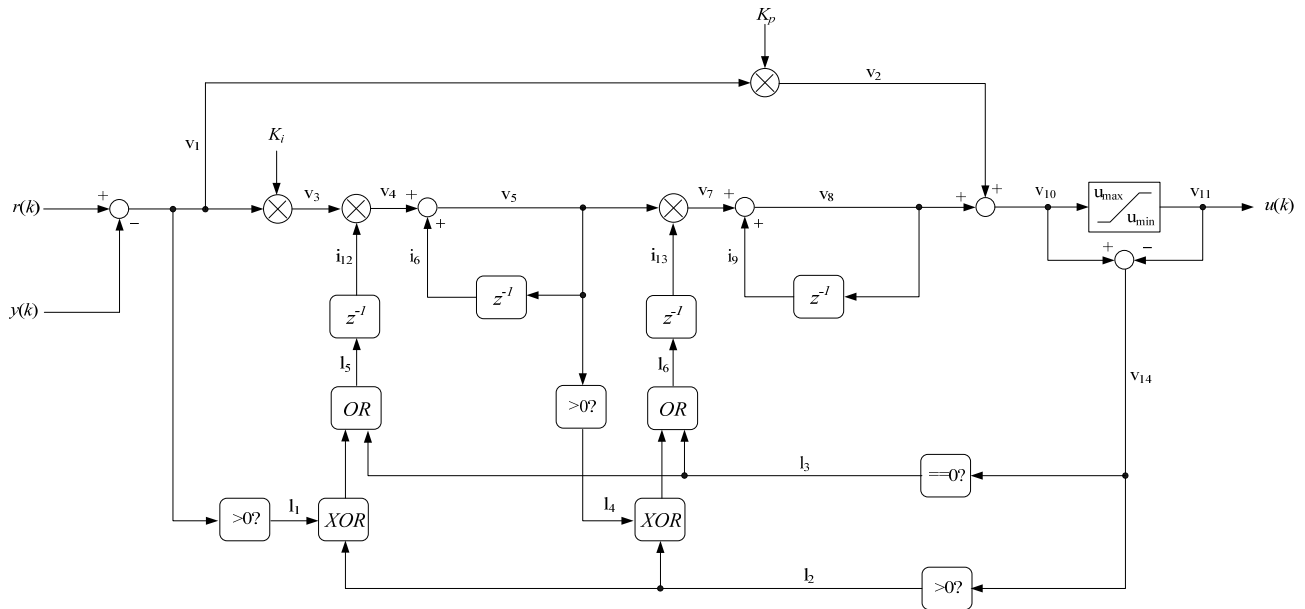

Figure 20. *DCL\_PI2 C1 architecture*

#### 3.5.3 Functions

<code>DCL_runPI2_C1</code>	<i>Run the Ideal Form PI2 Controller</i>
----------------------------	--

Header File: `DCLF32.h`

Source File: N/A

Declaration: `float32_t DCL_runPI2_C1(DCL_PI2 *p, float32_t rk, float32_t yk)`

Description: This function executes an ideal form PI2 controller on the FPU32. The function is coded in C.

Parameters: `p` The DCL\_PI2 structure  
`rk` The controller set-point reference  
`yk` The measured feedback

Return: The control effort

<b><i>DCL_resetPI2</i></b>	<b><i>Resets the PI2 Controller</i></b>
----------------------------	---

Header File: DCLF32.h

Source File: N/A

Declaration: `void DCL_resetPI2(DCL_PI2 *p)`

Description: This function resets the internal variables in the DCL\_PI2 structure to default values. Both integrator accumulators are set to zero, and the `err` field in the CSS sub-structure is set NONE. Note that the function is atomic.

Parameters: `p` The DCL\_PI2 structure

Return: Void

<b><i>DCL_updatePI2</i></b>	<b><i>Updates the PI2 Controller Parameters</i></b>
-----------------------------	---

Header File: DCLF32.h

Source File: N/A

Declaration: `void DCL_updatePI2(DCL_PI2 *p)`

Description: This function tests the `sts` field in the CSS sub-structure to determine whether a parameter update is required. If so, the parameters stored in the SPS sub-structure are copied into the PI2 structure and `sts` is cleared. Note that the function is atomic. Refer to section 2.4 for more information on updating controller parameters.

Parameters: `p` The DCL\_PI2 structure

Return: Void



**DCL\_fupdatePI2**

**Updates the PI2 Controller Parameters**

Header File: DCLF32.h  
 Source File: DCL\_futils.asm  
 Declaration: void DCL\_fupdatePI2(DCL\_PI2 \*p)  
 Description: This function tests the `sts` field in the CSS sub-structure to determine whether a parameter update is required. If so, the parameters stored in the SPS sub-structure are copied into the PI2 structure and `sts` is cleared. Note that the function is atomic. Refer to section 2.4 for more information on updating controller parameters. The function is implemented as an assembly module.  
 Parameters: p The DCL\_PI2 structure  
 Return: Void

**3.6 Direct Form 1 (First Order) Compensators**

**3.6.1 Description**

The DCL includes one first order compensator in Direct Form 1. The DF11 compensator implements a first order, or “simple lag”, type frequency response. The general form of discrete time first order transfer function is

$$\text{Equation 12. } F(z) = \frac{b_0 + b_1 z^{-1}}{1 + a_1 z^{-1}}$$

Denominator coefficients must be normalized accordingly. The corresponding difference equation is

$$\text{Equation 13. } u(k) = b_0 e(k) + b_1 e(k - 1) - a_1 u(k - 1)$$

A diagrammatic representation of the DF11 is shown below:

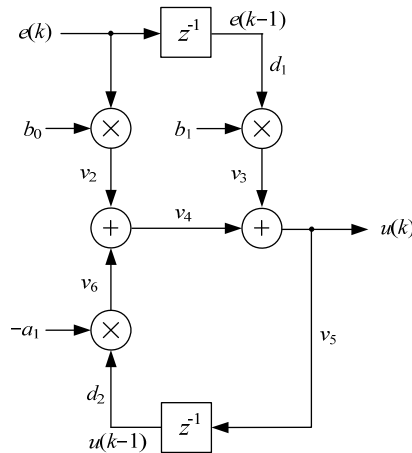

Figure 21. *DCL\_DF11 C1, C2, & L1 architecture*

### 3.6.2 Implementation

All DF11 functions use a common C structure to hold coefficients and data, defined in the header files `DCLF32.h` and `DCLCLA.h`.

It is the responsibility of the user to initialize coefficients and data prior to use. A set of default values is defined in the library header file and can be used with the variable declaration. An example of an initialized `DCL_DF11` structure declaration on FPU32 is shown below:

```
DCL_DF11 myCtrl = DF11_DEFAULTS;
```

### 3.6.3 Functions

<b><i>DCL_runDF11_C1</i></b>	<b><i>Run the DF11 Compensator</i></b>
------------------------------	--

Header File: `DCLF32.h`

Source File: `DCL_DF11_C1.asm`

Declaration: `float32_t DCL_runDF11_C1(DCL_DF11 *p, float32_t ek)`

Description: This function computes a first order control law using the Direct Form 1 structure. The function is coded in FPU32 assembly.

Parameters: `p`                      The `DCL_DF11` structure  
                   `ek`                      The servo error

Return:                      The control effort

<b><i>DCL_runDF11_C2</i></b>	<b><i>Run the DF11 Compensator</i></b>
------------------------------	--

Header File: `DCLF32.h`

Source File: N/A

Declaration: `float32_t DCL_runDF11_C1(DCL_DF11 *p, float32_t ek)`

Description: This function computes a first order control law using the Direct Form 1 structure. The function is coded in C.

Parameters: `p`                      The `DCL_DF11` structure  
                   `ek`                      The servo error

Return:                      The control effort

**DCL\_runDF11\_L1**

**Run the DF11 Compensator**

Header File: DCLCLA.h

Source File: DCL\_DF11\_L1.asm

Declaration: float32\_t DCL\_runDF11\_L1(DCL\_DF11\_CLA \*p, float32\_t ek)

Description: This function computes a first order control law using the Direct Form 1 structure. The function is coded in CLA assembly.

Parameters: p                    The DCL\_DF11\_CLA structure  
               ek                    The servo error

Return:                    The control effort

**DCL\_resetDF11**

**Resets the DF11 Compensator**

Header File: DCLF32.h

Source File: N/A

Declaration: void DCL\_resetDF11(DCL\_DF11 \*p)

Description: This function resets the internal variables in the DCL\_DF11 structure to default values. The forward and return path coefficients are configured to implement a unity gain response, and the `err` field in the CSS sub-structure is set NONE. Note that the function is atomic.

Parameters: p                    The DCL\_DF11 structure

Return:                    Void

**DCL\_updateDF11**

**Updates the DF11 Compensator Parameters**

Header File: DCLF32.h

Source File: N/A

Declaration: void DCL\_updateDF11(DCL\_DF11 \*p)

Description: This function tests the `sts` field in the CSS sub-structure to determine whether a parameter update is required. If so, the parameters stored in the SPS sub-structure are copied into the DF11 structure and `sts` is cleared. Note that the function is atomic. Refer to section 2.4 for more information on updating controller parameters.

Parameters: p                    The DCL\_DF11 structure

Return:                    Void

***DCL\_fupdateDF11***

***Updates the DF11 Controller Parameters***

Header File: DCLF32.h

Source File: DCL\_futils.asm

Declaration: void DCL\_fupdateDF11(DCL\_DF11 \*p)

Description: This function tests the `sts` field in the CSS sub-structure to determine whether a parameter update is required. If so, the parameters stored in the SPS sub-structure are copied into the DF11 structure and `sts` is cleared. Note that the function is atomic. Refer to section 2.4 for more information on updating controller parameters. The function is implemented as an assembly module.

Parameters: p                    The DCL\_DF11 structure

Return:                    Void

***DCL\_isStableDF11***

***Determines whether the DF11 Compensator is Stable***

Header File: DCLF32.h

Source File: N/A

Declaration: int16\_t DCL\_isStableDF11(DCL\_DF11 \*p)

Description: This function determines whether the coefficient set in the SPS sub-structure represent a stable compensator. If the pole magnitude is less than one, the function returns '1', indicating stability; otherwise the function returns '0'. Refer to section 1.3.9 for more information on compensator stability tests.

Parameters: p                    The DCL\_DF11 structure

Return:                    '1' if stable, otherwise '0'

***DCL\_loadDF11asZPK***

***Loads the DF11 Compensator from ZPK***

Header File: DCLF32.h

Source File: N/A

Declaration: void DCL\_loadDF11asZPK (DCL\_DF11 \*p, DCL\_ZPK3 \*q)

Description: This function loads the DF11 compensator coefficients in the SPS sub-structure from a 1-pole, 1-zero description held in a ZPK3 structure. Active coefficients are unaffected until the `DCL_updateDF11()` function is called. Refer to section 1.3.8 for more information on the ZPK3 structure.

Parameters: p                    The DCL\_DF11 structure

                  q                    The DCL\_ZPK3 structure

Return: Void

**DCL\_loadDF11asPI**      **Loads the DF11 Compensator from a PI Description**

Header File: DCLF32.h  
 Source File: N/A  
 Declaration: void DCL\_loadDF11asPI (DCL\_DF11 \*p, float32\_t Kp, float32\_t Ki)  
 Description: This function loads the DF11 compensator coefficients in the SPS sub-structure to emulate a series form PI controller. Active coefficients are unaffected until the DCL\_updateDF11 () function is called.  
 Parameters: p                    The DCL\_DF11 structure  
                  Kp                    The equivalent series form PI controller proportional gain  
                  Ki                    The equivalent series form PI controller integral gain  
 Return: Void

**3.7 Direct Form 1 (Third Order) Compensators**

**3.7.1 Description**

The Direct Form 1 (DF1) structure is a common type of discrete time control structure used to implement a control law or dynamical system model specified either as a pole-zero set, or as a rational polynomial in z (i.e. a discrete time transfer function). The DCL includes one third order DF1 compensator, denoted “DF13”.

In general, the Direct Form 1 structure is less numerically robust than the Direct Form 2 (see below), and for this reason users are encouraged to choose the latter type whenever possible. However, the DCL\_DF13 structure is very common in digital power supplies and for that reason is included in the library. The same function supports a second order control law after the superfluous coefficients (a<sub>3</sub> & b<sub>3</sub>) have been set to zero.

The general form of third order transfer function is

$$Equation\ 14.\ F(z) = \frac{b_0 + b_1z^{-1} + b_2z^{-2} + b_3z^{-3}}{1 + a_1z^{-1} + a_2z^{-2} + a_3z^{-3}}$$

Notice that the coefficients have been adjusted to normalize the highest power of z in the denominator. There is no notational standard for numbering of the controller coefficients; the notation used here has the advantage that the coefficient suffixes are the same as the delay line elements and this helps with clarity of the assembly code, however other notations may be found in the literature. The corresponding difference equation is

$$Equation\ 15.\ \begin{aligned} u(k) = & b_0e(k) + b_1e(k-1) + b_2e(k-2) + b_3e(k-3) \\ & - a_1u(k-1) - a_2u(k-2) - a_3u(k-3) \end{aligned}$$

The DF13 controller uses two, three-element delay lines to store previous input and output data required to compute  $u(k)$ . A diagrammatic representation is shown below.

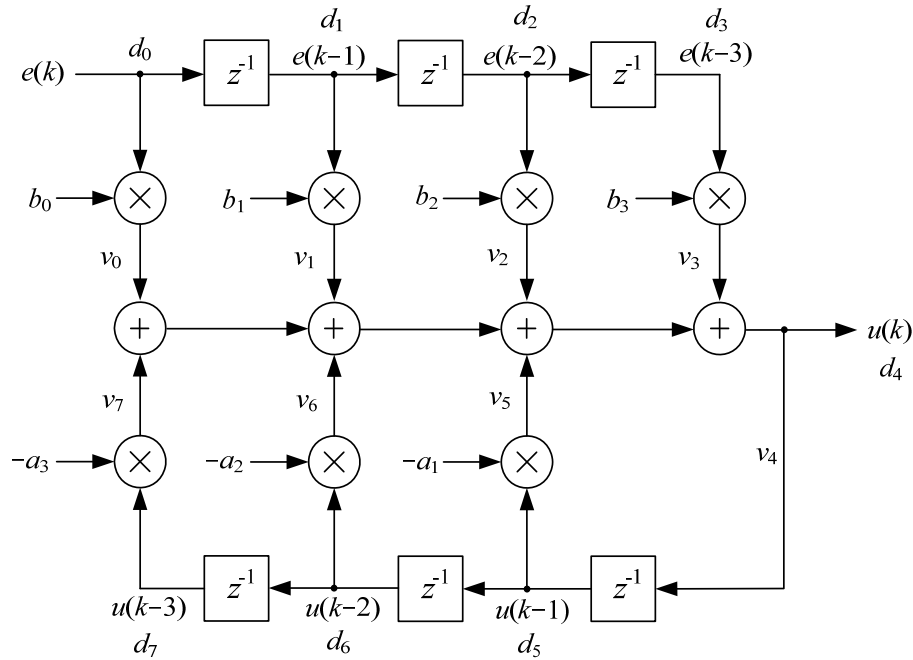

Figure 22. DCL\_DF13 C1, C4, & L1 architecture

The DF13 control law consists of seven multiplication operations which yield seven partial products, and six addition or subtraction operations which combine the partial products to obtain the compensator output,  $u(k)$ . When implemented in this way, the control law is referred to as the “full” DF13 form.

The DF13 control law can be re-structured to reduce control latency by pre-computing six of the seven partial products which are already known in the previous sample interval. The control law is then broken into two parts: the “immediate” part and the “partial” part.

The advantage of doing this is to reduce the “sample-to output” delay, or the time between  $e(k)$  being sampled, and a corresponding  $u(k)$  becoming available. By partially pre-computing the control law, the computation delay can be reduced to one multiplication and one addition.

In the  $k^{\text{th}}$  interval, the immediate part is computed.

Equation 16.  $u(k) = b_0e(k) + v(k - 1)$

Next, the  $v(k)$  partial result is pre-computed for use in the  $(k+1)^{\text{th}}$  interval.

Equation 17.  $v(k) = b_1e(k) + b_2e(k - 1) + b_3e(k - 2) - a_1u(k) - a_2u(k - 1) - a_3u(k - 2)$

Structurally, the pre-computed control law can be drawn as below:

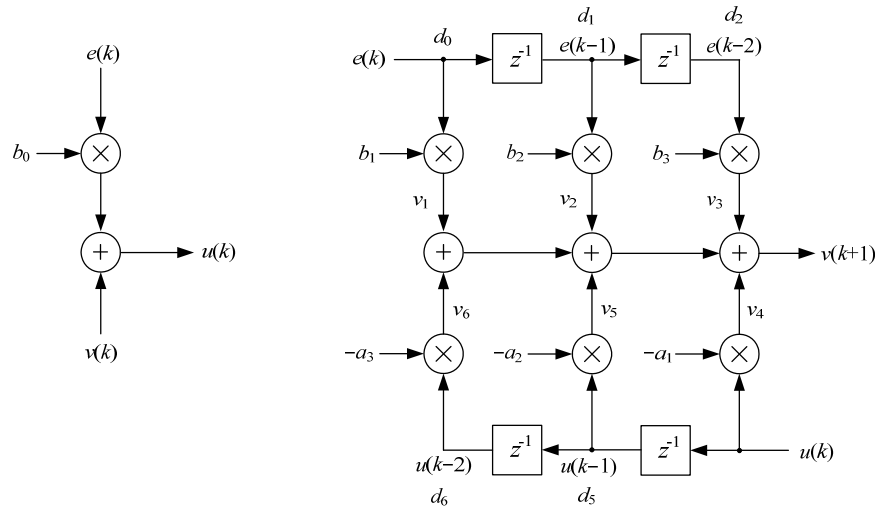

Figure 23.

**DCL\_DF13 C2, C3, C5, C6, L2, & L3 architecture**

The pre-computed structure allows the controller output ( $u(k)$ ) to be used as soon as it is computed. The remaining terms in the third order control law do not involve the newest input  $e(k)$  and therefore do not affect  $u(k)$ . These terms can be computed after  $u(k)$  has been applied to the control loop and the input-output latency of the controller is therefore reduced.

A further benefit of the pre-computed structure is that it allows the control effort to be clamped after the immediate part. Computation of the pre-computed part can be made dependent on the outcome of the clamp such that if  $u(k)$  matches or exceeds the clamp limits there is no point in pre-computing the next partial control variable and the computation can be avoided. The DCL includes three clamp functions intended for this purpose (see chapter 6).

**3.7.2 Implementation**

All DF13 functions use a common C structure to hold coefficients and data, defined in the header files `DCL.h` and `DCLCLA.h`.

The assignment of coefficients and data in the `DCL_DF13` structure to those in the diagram is shown below:

Coefficients		Data	
c[0]	$b_0$	d[0]	$e(k)$
c[1]	$b_1$	d[1]	$e(k-1)$
c[2]	$b_2$	d[2]	$e(k-2)$
c[3]	$b_3$	d[3]	$e(k-3)$
c[4]	$a_0$	d[4]	$u(k)$
c[5]	$a_1$	d[5]	$u(k-1)$
c[6]	$a_2$	d[6]	$u(k-2)$
c[7]	$a_3$	d[7]	$u(k-3)$

Figure 24. *DCL\_DF13 data & coefficient layout*

It is the responsibility of the user to initialize both arrays prior to use. A set of default values is defined in the library header file and can be used with the variable declaration. An example of an initialized DF13 structure declaration is shown below:

```
DCL_DF13 myCtrl = DF13_DEFAULTS;
```

To implement a full DF13 controller, the user might call:

```
uk = DCL_runDF13_C1(&df13, ek);
```

...where  $ek$  and  $uk$  are the controller input and output respectively, and  $df13$  is the controller structure.

To implement a pre-computed DF13 controller, the user might call:

```
uk = DCL_runDF13_C2(&df13, ek, vk);
```

```
vk = DCL_runDF13_C3(&df13, ek, uk);
```

...where  $vk$  is an intermediate float variable. This arrangement allows the user to make use of the output immediately by placing instructions between the two lines above to use the newest value of  $uk$ .

For applications where it is necessary to restrict the output of the compensator, a clamp function can be used as follows.

```
uk = DCL_runDF13_C2(&df13, ek, vk);
s = DCL_runClamp_C1(&uk, upperLim, lowerLim);
if (0U == s)
{
    vk = DCL_runDF13_C3(&df13, ek, uk);
}
```

The clamp function limits the controller output to lie between “lowerLim” and “upperLim” and sets the unsigned integer “s” to 1 if that range is exceeded. The pre-computed part



of the controller will only be executed when the immediate result is in range. Refer to section 4.1 for information on the clamp functions.

### 3.7.3 Functions

#### ***DCL\_runDF13\_C1***

#### ***Run the DF13 Full Compensator***

Header File: DCLF32.h

Source File: DCL\_DF13\_C1.asm

Declaration: float32\_t DCL\_runDF13\_C1(DCL\_DF13 \*p, float32\_t ek)

Description: This function computes a full third order control law using the Direct Form 1 structure. The function is coded in FPU32 assembly.

Parameters: p                    The DCL\_DF13 structure  
               ek                    The servo error

Return:                    The control effort

#### ***DCL\_runDF13\_C2***

#### ***Run the Immediate DF13 Compensator***

Header File: DCLF32.h

Source File: DCL\_DF13\_C2C3.asm

Declaration: float32\_t DCL\_runDF13\_C2(DCL\_DF13 \*p, float32\_t ek, float32\_t vk)

Description: This function computes the immediate part of the pre-computed DF13 controller. The function is coded in FPU32 assembly.

Parameters: p                    The DCL\_DF13 structure  
               ek                    The servo error  
               vk                    The pre-computed partial control effort

Return:                    The control effort

#### ***DCL\_runDF13\_C3***

#### ***Run the Partial DF13 Compensator***

Header File: DCLF32.h

Source File: DCL\_DF13\_C2C3.asm

Declaration: float32\_t DCL\_runDF13\_C3(DCL\_DF13 \*p, float32\_t ek, float32\_t uk)

Description: This function computes the partial result of the pre-computed DF13 controller. The function is coded in FPU32 assembly.

Parameters: p                    The DCL\_DF13 structure

ek                    The servo error  
 uk                    The control effort in the previous sample interval  
 Return:              The control effort

<b>DCL_runDF13_C4</b>	<b><i>Run the DF13 Full Compensator</i></b>
-----------------------	---

Header File:    DCLF32.h  
 Source File:    N/A  
 Declaration:   float32\_t DCL\_runDF13\_C4(DCL\_DF13 \*p, float32\_t ek)  
 Description:    This function computes a full third order control law using the Direct Form 1 structure, and is identical in structure and operation to the C1 form. The function is coded in inline C.  
 Parameters:    p                    The DCL\_DF13 structure  
                   ek                    The servo error  
 Return:           The control effort

<b>DCL_runDF13_C5</b>	<b><i>Run the Immediate DF13 Compensator</i></b>
-----------------------	--

Header File:    DCLF32.h  
 Source File:    N/A  
 Declaration:   float32\_t DCL\_runDF13\_C5(DCL\_DF13 \*p, float32\_t ek, float32\_t vk)  
 Description:    This function computes the immediate part of the pre-computed DF13 controller. The function is identical in structure and operation to the C2 form. The function is coded in inline C.  
 Parameters:    p                    The DCL\_DF13 structure  
                   ek                    The servo error  
                   vk                    The pre-computed partial control effort  
 Return:           The control effort

<b>DCL_runDF13_C6</b>	<b><i>Run the Partial DF13 Compensator</i></b>
-----------------------	--

Header File:    DCLF32.h  
 Source File:    N/A  
 Declaration:   float32\_t DCL\_runDF13\_C6(DCL\_DF13 \*p, float32\_t ek, float32\_t uk)  
 Description:    This function computes the partial result of the pre-computed DF13 controller. The function is identical in structure and operation to the C3 form. The function is coded in inline C.

Parameters: p                    The DCL\_DF13 structure  
               ek                    The servo error  
               uk                    The control effort in the previous sample interval

Return:                    The control effort

**DCL\_runDF13\_L1**

**Run the DF13 Full Compensator on the CLA**

Header File:    DCLCLA.h

Source File:    DCL\_DF13\_L1.asm

Declaration:    float32\_t DCL\_runDF13\_L1(DCL\_DF13\_CLA \*p, float32\_t ek)

Description:    This function computes a full third order control law using the Direct Form 1 structure, and is identical in structure and operation to the C1 form. The function is coded in CLA assembly language.

Parameters:    p                    The DCL\_DF13\_CLA structure  
                   ek                    The servo error

Return:                    The control effort

**DCL\_runDF13\_L2**

**Run the Immediate DF13 Compensator on the CLA**

Header File:    DCLCLA.h

Source File:    DCL\_DF13\_L2L3.asm

Declaration:    float32\_t DCL\_runDF13\_L2(DCL\_DF13\_CLA \*p, float32\_t ek, float32\_t vk)

Description:    This function computes the immediate part of the pre-computed DF13 controller. The function is identical in structure and operation to the C2 form. The function is coded in CLA assembly language.

Parameters:    p                    The DCL\_DF13\_CLA structure  
                   ek                    The servo error  
                   vk                    The pre-computed partial control effort

Return:                    The control effort

**DCL\_runDF13\_L3**

**Run the Partial DF13 Compensator on the CLA**

Header File:    DCLCLA.h

Source File:    DCL\_DF13\_L2L3.asm

Declaration:    float32\_t DCL\_runDF13\_L3(DCL\_DF13\_CLA \*p, float32\_t ek, float32\_t uk)

Description: This function computes the partial result of the pre-computed DF13 controller. The function is identical in structure and operation to the C3 form. The function is coded in CLA assembly language.

Parameters: p            The DCL\_DF13\_CLA structure  
 ek                    The servo error  
 uk                    The control effort in the previous sample interval

Return:                The control effort

<b>DCL_runDF13_L4</b>	<b><i>Run the DF13 Full Compensator on the CLA</i></b>
-----------------------	--

Header File:    DCLCLA.h

Source File:    N/A

Declaration:    float32\_t DCL\_runDF13\_L4(DCL\_DF13\_CLA \*p, float32\_t ek)

Description:    This function computes a full third order control law using the Direct Form 1 structure, and is identical in structure and operation to the C4 form. The function is coded in C.

Parameters:    p                    The DCL\_DF13\_CLA structure  
 ek                    The servo error

Return:            The control effort

<b>DCL_runDF13_L5</b>	<b><i>Run the Immediate DF13 Compensator on the CLA</i></b>
-----------------------	---

Header File:    DCLCLA.h

Source File:    N/A

Declaration:    float32\_t DCL\_runDF13\_L5(DCL\_DF13\_CLA \*p, float32\_t ek, float32\_t vk)

Description:    This function computes the immediate part of the pre-computed DF13 controller. The function is identical in structure and operation to the C2 form. The function is coded in C.

Parameters:    p                    The DCL\_DF13\_CLA structure  
 ek                    The servo error  
 vk                    The pre-computed partial control effort

Return:            The control effort

<b>DCL_runDF13_L6</b>	<b><i>Run the Partial DF13 Compensator on the CLA</i></b>
-----------------------	---

Header File:    DCLCLA.h

Source File: N/A

Declaration: float32\_t DCL\_runDF13\_L6(DCL\_DF13\_CLA \*p, float32\_t ek, float32\_t uk)

Description: This function computes the partial result of the pre-computed DF13 controller. The function is identical in structure and operation to the C3 form. The function is coded in C.

Parameters: p The DCL\_DF13\_CLA structure  
 ek The servo error  
 uk The control effort in the previous sample interval

Return: The control effort

**DCL\_resetDF13**

**Resets the DF13 Compensator**

Header File: DCLF32.h

Source File: N/A

Declaration: void DCL\_resetDF13(DCL\_DF13 \*p)

Description: This function resets the internal variables in the DCL\_DF13 structure to default values. The forward and return path coefficients are configured to implement a unity gain response, and the `err` field in the CSS sub-structure is set NONE. Note that the function is atomic.

Parameters: p The DCL\_DF13 structure

Return: Void

**DCL\_updateDF13**

**Updates the DF13 Compensator Parameters**

Header File: DCLF32.h

Source File: N/A

Declaration: void DCL\_updateDF13(DCL\_DF13 \*p)

Description: This function tests the `sts` field in the CSS sub-structure to determine whether a parameter update is required. If so, the parameters stored in the SPS sub-structure are copied into the DF13 structure and `sts` is cleared. Note that the function is atomic. Refer to section 2.4 for more information on updating controller parameters.

Parameters: p The DCL\_DF13 structure

Return: Void

***DCL\_fupdateDF13***

***Updates the DF13 Controller Parameters***

Header File: DCLF32.h

Source File: DCL\_futils.asm

Declaration: void DCL\_fupdateDF13(DCL\_DF13 \*p)

Description: This function tests the `sts` field in the CSS sub-structure to determine whether a parameter update is required. If so, the parameters stored in the SPS sub-structure are copied into the DF13 structure and `sts` is cleared. Note that the function is atomic. Refer to section 2.4 for more information on updating controller parameters. The function is implemented as an assembly module.

Parameters: p                    The DCL\_DF13 structure

Return:                    Void

***DCL\_isStableDF13***

***Determines whether the DF13 Compensator is Stable***

Header File: DCLF32.h

Source File: N/A

Declaration: int16\_t DCL\_isStableDF13(DCL\_DF13 \*p)

Description: This function determines whether the coefficient set in the SPS sub-structure represent a stable compensator. If the pole magnitude is less than one, the function returns '1', indicating stability; otherwise the function returns '0'. Refer to section 1.3.9 for more information on compensator stability tests.

Parameters: p                    The DCL\_DF13 structure

Return:                    '1' if stable, otherwise '0'

***DCL\_loadDF13asZPK***

***Loads the DF13 Compensator from ZPK***

Header File: DCLF32.h

Source File: N/A

Declaration: void DCL\_loadDF13asZPK (DCL\_DF13 \*p, DCL\_ZPK3 \*q)

Description: This function loads the DF13 compensator coefficients in the SPS sub-structure from a 3-pole, 3-zero description held in a ZPK3 structure. Active coefficients are unaffected until the `DCL_updateDF13()` function is called. Refer to section 1.3.8 for more information on the ZPK3 structure.

Parameters: p                    The DCL\_DF13 structure

                  q                    The DCL\_ZPK3 structure

Return:                    Void

### 3.8 Direct Form 2 (Second Order) Compensators

#### 3.8.1 Description

The C2000 Digital Controller Library contains a second order implementation of the Direct Form 2 controller structure, denoted “DCL\_DF22”. This structure is sometimes referred to as a “bi-quad” filter and is commonly used in a cascaded chain to build up digital filters of high order.

The transfer function of a second order discrete time compensator is

$$\text{Equation 18. } F(z) = \frac{b_0 + b_1z^{-1} + b_2z^{-2}}{1 + a_1z^{-1} + a_2z^{-2}}$$

The corresponding difference equation is

$$\text{Equation 19. } u(k) = b_0e(k) + b_1e(k-1) + b_2e(k-2) - a_1u(k-1) - a_2u(k-2)$$

A diagrammatic representation of the full Direct Form 2 realization is shown below:

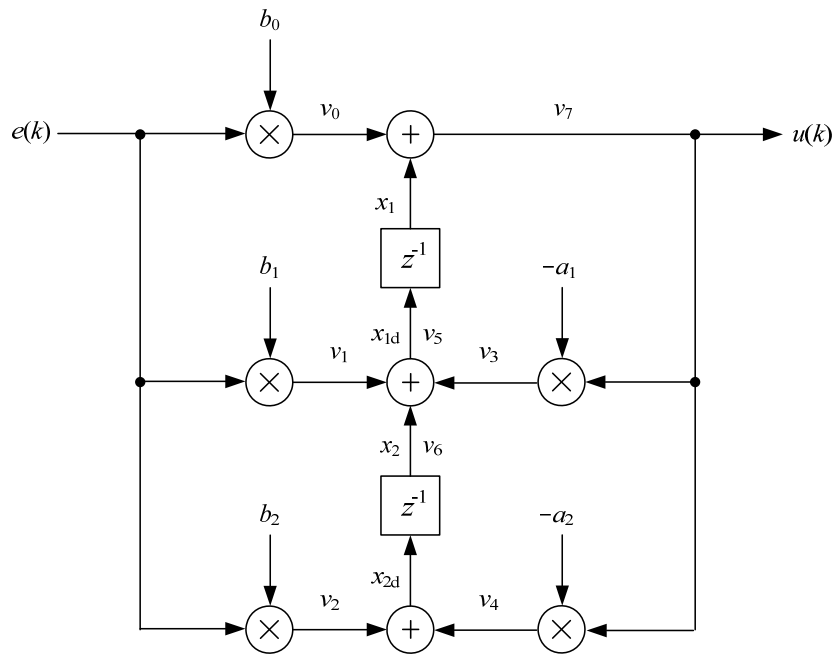

Figure 25. DCL\_DF22 C1, C4,L1, & L4 architecture

As with the DCL\_DF13 compensator, sample-to-output delay can be reduced through the use of pre-computation. The immediate and pre-computed control laws are as follows. In the  $k^{\text{th}}$  interval, the immediate part is computed.

Equation 20.  $u(k) = b_0e(k) + v(k)$

Next, the  $v(k)$  partial result is pre-computed for use in the  $(k+1)^{\text{th}}$  interval.

Equation 21.  $v(k+1) = b_1e(k) + b_2e(k-1) - a_1u(k) - a_2u(k-1)$

The pre-computed form of DCL\_DF22 is shown in the following diagrams.

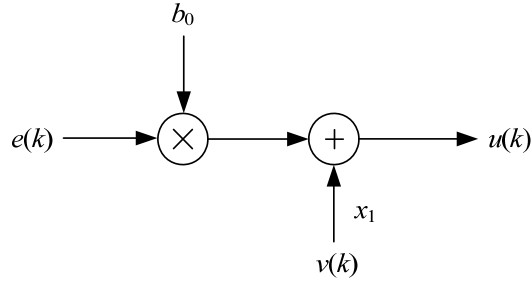

Figure 26. DCL\_DF22 C2, C5, & L2 architecture

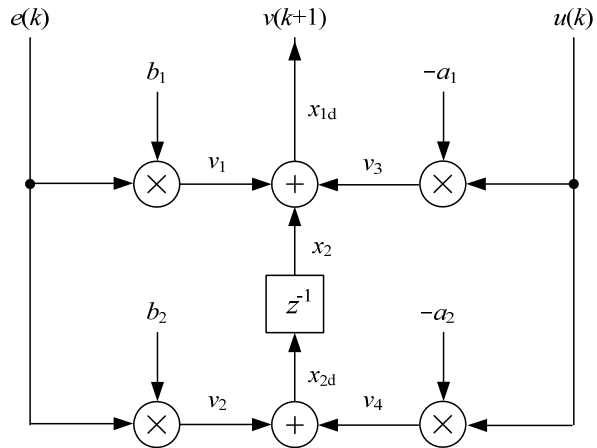

Figure 27. DCL\_DF22 C3, C6, & L3 architecture

Notice that pre-computation is a little different from the Direct Form 1 case because the intermediate value exists as one of the internal states and is therefore automatically stored as “x1” in the DCL\_DF22 structure. Therefore it is not necessary to create a separate variable to store  $v(k)$ .

### 3.8.2 Implementation

All DF22 functions use a common C structure to hold coefficients and data, defined in the header file `DCL.h` and `DCLCLA.h`.



It is the responsibility of the user to initialize both arrays prior to use. A set of default values is defined in the library header file and can be used with the variable declaration. An example of an initialized DCL\_DF22 structure declaration is shown below:

```
DF22 myCtrl = DF22_DEFAULTS;
```

An example of a pre-computed DF22 controller can be found in section 5.1.

### 3.8.3 Functions

#### **DCL\_runDF22\_C1**

#### **Run the DF22 Full Compensator**

Header File: DCLF32.h  
 Source File: DCL\_DF22\_C1.asm  
 Declaration: float32\_t DCL\_runDF22\_C1(DCL\_DF22 \*p, float32\_t ek)  
 Description: This function computes a full second order control law using the Direct Form 2 structure. The function is coded in FPU32 assembly.  
 Parameters: p                    The DCL\_DF22 structure  
               ek                    The servo error  
 Return:                    The control effort

#### **DCL\_runDF22\_C2**

#### **Run the Immediate DF22 Compensator**

Header File: DCLF32.h  
 Source File: DCL\_DF22\_C2C3.asm  
 Declaration: float32\_t DCL\_runDF22\_C2(DCL\_DF22 \*p, float32\_t ek)  
 Description: This function computes the immediate part of the pre-computed DF22 controller. The function is coded in FPU32 assembly.  
 Parameters: p                    The DCL\_DF22 structure  
               ek                    The servo error  
 Return:                    The control effort

#### **DCL\_runDF22\_C3**

#### **Run the Partial DF22 Compensator**

Header File: DCLF32.h  
 Source File: DCL\_DF22\_C2C3.asm  
 Declaration: void DCL\_runDF22\_C3(DCL\_DF22 \*p, float32\_t ek, float32\_t uk)  
 Description: This function computes the partial result of the pre-computed DF22 controller. The function is coded in FPU32 assembly.

Parameters: p            The DCL\_DF22 structure  
               ek            The servo error  
               uk            The control effort in the previous sample interval

Return:            The control effort

***DCL\_runDF22\_C4***

***Run the DF22 Full Compensator***

Header File:    DCLF32.h  
 Source File:    N/A  
 Declaration:   float32\_t DCL\_runDF22\_C4(DCL\_DF22 \*p, float32\_t ek)  
 Description:    This function computes a full second order control law using the Direct Form 2 structure, and is identical in structure and operation to the C1 form. The function is coded in inline C.  
 Parameters:    p            The DCL\_DF22 structure  
                   ek            The servo error  
 Return:            The control effort

***DCL\_runDF22\_C5***

***Run the Immediate DF22 Compensator***

Header File:    DCLF32.h  
 Source File:    N/A  
 Declaration:   float32\_t DCL\_runDF22\_C5(DCL\_DF22 \*p, float32\_t ek)  
 Description:    This function computes the immediate part of the pre-computed DF22 controller. The function is identical in structure and operation to the C2 form. The function is coded in inline C.  
 Parameters:    p            The DCL\_DF22 structure  
                   ek            The servo error  
 Return:            The control effort

***DCL\_runDF22\_C6***

***Run the Partial DF22 Compensator***

Header File:    DCLF32.h  
 Source File:    N/A  
 Declaration:   float32\_t DCL\_runDF22\_C6(DCL\_DF22 \*p, float32\_t ek, float32\_t uk)  
 Description:    This function computes the partial result of the pre-computed DF22 controller. The function is identical in structure and operation to the C3 form. The function is coded in inline C.

Parameters: p                    The DCL\_DF22 structure  
               ek                    The servo error  
               uk                    The control effort in the previous sample interval

Return:                    The control effort

**DCL\_runDF22\_L1**

**Run the DF22 Full Compensator on the CLA**

Header File:    DCLCLA.h

Source File:    DCL\_DF22\_L1.asm

Declaration:    float32\_t DCL\_runDF22\_L1(DCL\_DF22\_CLA \*p, float32\_t ek)

Description:    This function computes a full third order control law using the Direct Form 2 structure, and is identical in structure and operation to the C1 form. The function is coded in CLA assembly language.

Parameters:    p                    The DCL\_DF22\_CLA structure  
                   ek                    The servo error

Return:                    The control effort

**DCL\_runDF22\_L2**

**Run the Immediate DF22 Compensator on the CLA**

Header File:    DCLCLA.h

Source File:    DCL\_DF22\_L2L3.asm

Declaration:    float32\_t DCL\_runDF22\_L2(DCL\_DF22\_CLA \*p, float32\_t ek)

Description:    This function computes the immediate part of the pre-computed DF22 controller. The function is identical in structure and operation to the C2 form. The function is coded in CLA assembly language.

Parameters:    p                    The DCL\_DF22\_CLA structure  
                   ek                    The servo error

Return:                    The control effort

**DCL\_runDF22\_L3**

**Run the Partial DF22 Compensator on the CLA**

Header File:    DCLCLA.h

Source File:    DCL\_DF22\_L2L3.asm

Declaration:    float32\_t DCL\_runDF22\_L3(DCL\_DF22\_CLA \*p, float32\_t ek, float32\_t uk)

Description:    This function computes the partial result of the pre-computed DF22 controller. The function is identical in structure and operation to the C3 form. The function is coded in CLA assembly language.

Parameters: p            The DCL\_DF22\_CLA structure  
               ek            The servo error  
               uk            The control effort in the previous sample interval

Return:            The control effort

***DCL\_runDF22\_L4***

***Run the DF22 Full Compensator on the CLA***

Header File:    DCLCLA.h  
 Source File:    N/A  
 Declaration:   float32\_t DCL\_runDF22\_L4(DCL\_DF22\_CLA \*p, float32\_t ek)  
 Description:    This function computes a full third order control law using the Direct Form 2 structure, and is identical in structure and operation to the C1 form. The function is coded in C.

Parameters:    p            The DCL\_DF22\_CLA structure  
               ek            The servo error

Return:            The control effort

***DCL\_resetDF22***

***Resets the DF22 Compensator***

Header File:    DCLF32.h  
 Source File:    N/A  
 Declaration:    void DCL\_resetDF22(DCL\_DF22 \*p)  
 Description:    This function resets the internal variables in the DCL\_DF22 structure to default values. The forward and return path coefficients are configured to implement a unity gain response, and the `err` field in the CSS sub-structure is set NONE. Note that the function is atomic.

Parameters:    p            The DCL\_DF22 structure

Return:            Void

***DCL\_updateDF22***

***Updates the DF22 Compensator Parameters***

Header File:    DCLF32.h  
 Source File:    N/A  
 Declaration:    void DCL\_updateDF22(DCL\_DF22 \*p)

Description: This function tests the `sts` field in the CSS sub-structure to determine whether a parameter update is required. If so, the parameters stored in the SPS sub-structure are copied into the DF22 structure and `sts` is cleared. Note that the function is atomic. Refer to section 2.4 for more information on updating controller parameters.

Parameters: `p` The DCL\_DF22 structure

Return: Void

**DCL\_fupdateDF22**

**Updates the DF22 Controller Parameters**

Header File: DCLF32.h

Source File: DCL\_futils.asm

Declaration: void DCL\_fupdateDF22(DCL\_DF22 \*p)

Description: This function tests the `sts` field in the CSS sub-structure to determine whether a parameter update is required. If so, the parameters stored in the SPS sub-structure are copied into the DF22 structure and `sts` is cleared. Note that the function is atomic. Refer to section 2.4 for more information on updating controller parameters. The function is implemented as an assembly module.

Parameters: `p` The DCL\_DF22 structure

Return: Void

**DCL\_isStableDF22**

**Determines whether the DF22 Compensator is Stable**

Header File: DCLF32.h

Source File: N/A

Declaration: int16\_t DCL\_isStableDF22(DCL\_DF22 \*p)

Description: This function determines whether the coefficient set in the SPS sub-structure represent a stable compensator. If the pole magnitude is less than one, the function returns '1', indicating stability; otherwise the function returns '0'. Refer to section 1.3.9 for more information on compensator stability tests.

Parameters: `p` The DCL\_DF22 structure

Return: '1' if stable, otherwise '0'

**DCL\_loadDF22asZPK**

**Loads the DF22 Compensator from ZPK**

Header File: DCLF32.h

Source File: N/A

Declaration: void DCL\_loadDF22asZPK (DCL\_DF22 \*p, DCL\_ZPK3 \*q)

Description: This function loads the DF22 compensator coefficients in the SPS sub-structure from a 2-pole, 2-zero description held in a ZPK3 structure. Active coefficients are unaffected until the `DCL_updateDF22()` function is called. Refer to section 1.3.8 for more information on the ZPK3 structure.

Parameters: p            The DCL\_DF22 structure  
q                        The DCL\_ZPK3 structure

Return:                Void

**DCL\_loadDF22asZwn                        Loads the DF22 Compensator from  $\zeta$  and  $\omega_n$**

Header File:    DCLF32.h

Source File:    N/A

Declaration:    void DCL\_loadDF22asZwn (DCL\_DF22 \*p , float32\_t z, float32\_t wn)

Description:    This function loads the DF22 compensator coefficients in the SPS sub-structure from a classical second order transfer function expressed in terms of damping ratio ( $\zeta$ ) and un-damped natural frequency ( $\omega_n$ ). This function may be useful, for example, when emulating a plant model for control loop testing. The prototype transfer function is

Equation 22. 
$$\frac{\omega_n^2}{s^2 + 2\zeta\omega_n s + \omega_n^2}$$

Discrete emulation is carried out using a Tustin transformation and the coefficients loaded into the shadow parameter set. Active coefficients are unaffected until the `DCL_updateDF22()` function is called.

Parameters: p            The DCL\_DF22 structure  
z                        The damping ratio  
wn                      The un-damped natural frequency in rad/s

Return:                Void

**DCL\_loadDF22asParallelPID                Loads the DF22 Compensator from a PID Description**

Header File:    DCLF32.h

Source File:    N/A

Declaration:    void DCL\_loadDF22asParallelPID (DCL\_22 \*p, float32\_t Kp, float32\_t Ki, float32\_t Kd, float32\_t fc)

Description:    This function loads the DF22 compensator coefficients in the SPS sub-structure to emulate a parallel form PID controller. Active coefficients are unaffected until the `DCL_updateDF22()` function is called.

Parameters: p            The DCL\_DF22 structure

	Kp	The equivalent parallel form PID controller proportional gain
	Ki	The equivalent parallel form PID controller integral gain
	Kd	The equivalent parallel form PID controller derivative gain
	fc	The equivalent derivative filter bandwidth in Hz
Return:	Void	

<b>DCL_loadDF22asSeriesPID</b>	<b>Loads the DF22 Compensator from a PID Description</b>
--------------------------------	--

Header File:	DCLF32.h										
Source File:	N/A										
Declaration:	void DCL_loadDF22asSeriesPID (DCL_22 *p, float32_t Kp, float32_t Ki, float32_t Kd, float32_t fc )										
Description:	This function loads the DF22 compensator coefficients in the SPS sub-structure to emulate a series form PID controller. Active coefficients are unaffected until the DCL_updateDF22 ( ) function is called.										
Parameters:	<table> <tr> <td>p</td> <td>The DCL_DF22 structure</td> </tr> <tr> <td>Kp</td> <td>The equivalent series form PID controller proportional gain</td> </tr> <tr> <td>Ki</td> <td>The equivalent series form PID controller integral gain</td> </tr> <tr> <td>Kd</td> <td>The equivalent series form PID controller derivative gain</td> </tr> <tr> <td>fc</td> <td>The equivalent derivative filter bandwidth in Hz</td> </tr> </table>	p	The DCL_DF22 structure	Kp	The equivalent series form PID controller proportional gain	Ki	The equivalent series form PID controller integral gain	Kd	The equivalent series form PID controller derivative gain	fc	The equivalent derivative filter bandwidth in Hz
p	The DCL_DF22 structure										
Kp	The equivalent series form PID controller proportional gain										
Ki	The equivalent series form PID controller integral gain										
Kd	The equivalent series form PID controller derivative gain										
fc	The equivalent derivative filter bandwidth in Hz										
Return:	Void										

### 3.9 Direct Form 2 (Third Order) Compensators

#### 3.9.1 Description

The third order Direct Form 2 compensator (DF23) is similar in all respects to the DF22 compensator. Separate full and pre-computed forms are supplied in C and assembly for computation on the FPU32, and in assembly for computation on the CLA.

The control law is the same as the DF13 compensator.

Equation 23.

$$u(k) = b_0e(k) + b_1e(k - 1) + b_2e(k - 2) + b_3e(k - 3) - a_1u(k - 1) - a_2u(k - 2) - a_3u(k - 3)$$

A diagrammatic representation of the full third order Direct Form 2 compensator is shown below:

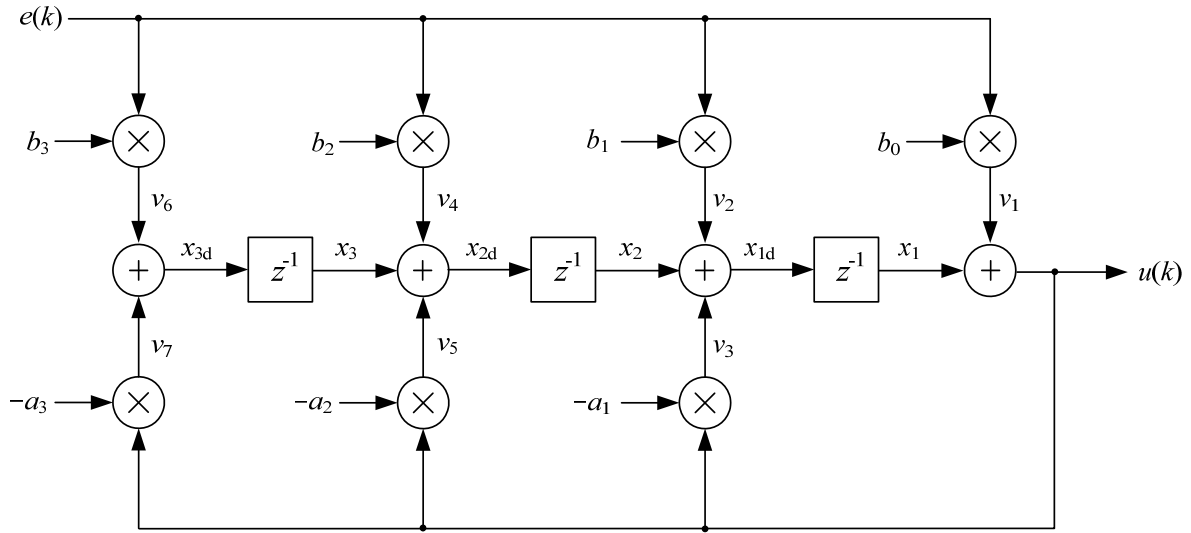

Figure 28. DCL\_DF23 C1, C4, & L1 architecture

Sample-to-output delay can be reduced through the use of pre-computation, in a similar way to the DF22 compensator. In the  $k^{\text{th}}$  interval, the immediate part is computed.

Equation 24.  $u(k) = b_0 e(k) + v(k)$

Next, the  $v(k)$  partial result is pre-computed for use in the  $(k+1)^{\text{th}}$  interval.

Equation 25.  $v(k+1) = b_1 e(k) + b_2 e(k-1) + b_3 e(k-2) - a_1 u(k) - a_2 u(k-1) - a_3 u(k-2)$

The pre-computed form of DF23 is shown in the following diagrams:

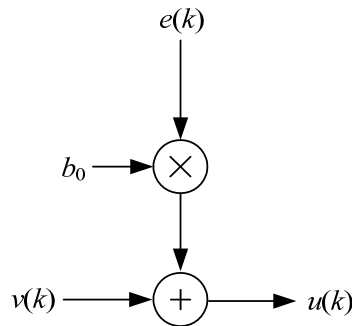

Figure 29. DCL\_DF23 C2, C5, & L2 architecture



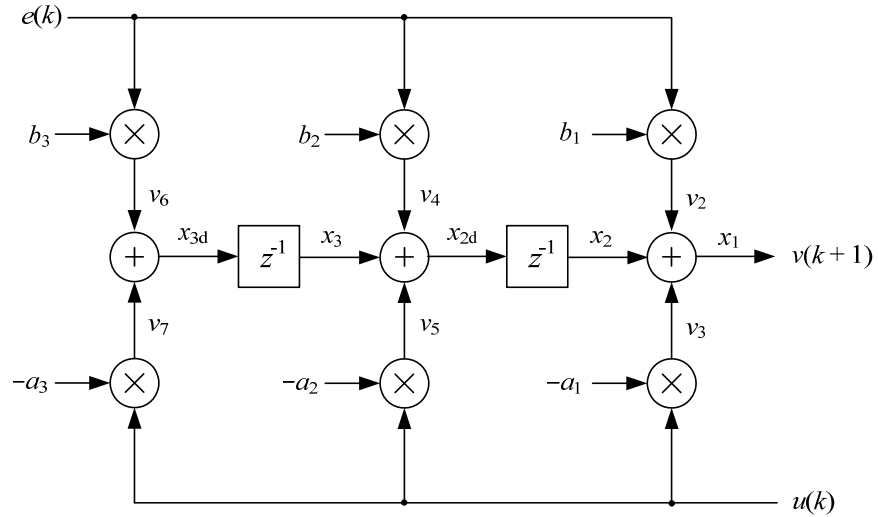

Figure 30. DCL\_DF23 C3, C6, & L3 architecture

### 3.9.2 Implementation

All DF23 functions use a common C structure to hold coefficients and data, defined in the header file `DCL.h` and `DCLCLA.h`.

It is the responsibility of the user to initialize both arrays prior to use. A set of default values is defined in the library header file and can be used with the variable declaration. An example of an initialized DCL\_DF23 structure declaration is shown below:

```
DCL_DF23 myCtrl = DF23_DEFAULTS;
```

An example of a pre-computed DF23 controller can be found in section 5.2.

### 3.9.3 Functions

<b>DCL_runDF23_C1</b>	<b>Run the DF23 Full Compensator</b>
-----------------------	--------------------------------------

- Header File: DCLF32.h
- Source File: DCL\_DF23\_C1.asm
- Declaration: `float32_t DCL_runDF23_C1(DCL_DF23 *p, float32_t ek)`
- Description: This function computes a full third order control law using the Direct Form 2 structure. The function is coded in FPU32 assembly.
- Parameters:
  - `p`                    The DCL\_DF23 structure
  - `ek`                    The servo error
- Return:                The control effort

***DCL\_runDF23\_C2***

***Run the Immediate DF23 Compensator***

Header File: DCLF32.h

Source File: DCL\_DF23\_C2C3.asm

Declaration: float32\_t DCL\_runDF23\_C2(DCL\_DF23 \*p, float32\_t ek)

Description: This function computes the immediate part of the pre-computed DF23 controller. The function is coded in FPU32 assembly.

Parameters: p                    The DCL\_DF23 structure  
               ek                    The servo error

Return:                    The control effort

***DCL\_runDF23\_C3***

***Run the Partial DF23 Compensator***

Header File: DCLF32.h

Source File: DCL\_DF23\_C2C3.asm

Declaration: void DCL\_runDF23\_C3(DCL\_DF23 \*p, float32\_t ek, float32\_t uk)

Description: This function computes the partial result of the pre-computed DF23 controller. The function is coded in FPU32 assembly.

Parameters: p                    The DCL\_DF23 structure  
               ek                    The servo error  
               uk                    The control effort in the previous sample interval

Return:                    The control effort

***DCL\_runDF23\_C4***

***Run the DF23 Full Compensator***

Header File: DCLF32.h

Source File: N/A

Declaration: float32\_t DCL\_runDF23\_C4(DCL\_DF23 \*p, float32\_t ek)

Description: This function computes a full third order control law using the Direct Form 1 structure, and is identical in structure and operation to the C1 form. The function is coded in inline C.

Parameters: p                    The DCL\_DF23 structure  
               ek                    The servo error

Return:                    The control effort

**DCL\_runDF23\_C5**

**Run the Immediate DF23 Compensator**

Header File: DCLF32.h

Source File: N/A

Declaration: float32\_t DCL\_runDF23\_C5(DCL\_DF23 \*p, float32\_t ek)

Description: This function computes the immediate part of the pre-computed DF23 controller. The function is identical in structure and operation to the C2 form. The function is coded in inline C.

Parameters: p                    The DCL\_DF23 structure  
                   ek                    The servo error

Return: The control effort

**DCL\_runDF23\_C6**

**Run the Partial DF23 Compensator**

Header File: DCLF32.h

Source File: N/A

Declaration: float32\_t DCL\_runDF23\_C6(DCL\_DF23 \*p, float32\_t ek, float32\_t uk)

Description: This function computes the partial result of the pre-computed DF23 controller. The function is identical in structure and operation to the C3 form. The function is coded in inline C.

Parameters: p                    The DCL\_DF23 structure  
                   ek                    The servo error  
                   uk                    The control effort in the previous sample interval

Return: The control effort

**DCL\_runDF23\_L1**

**Run the DF23 Full Compensator on the CLA**

Header File: DCLCLA.h

Source File: DCL\_DF23\_L1.asm

Declaration: float32\_t DCL\_runDF23\_L1(DCL\_DF23\_CLA \*p, float32\_t ek)

Description: This function computes a full third order control law using the Direct Form 2 structure, and is identical in structure and operation to the C1 form. The function is coded in CLA assembly language.

Parameters: p                    The DCL\_DF23\_CLA structure  
                   ek                    The servo error

Return: The control effort

**DCL\_runDF23\_L2**

**Run the Immediate DF23 Compensator on the CLA**

Header File: DCLCLA.h

Source File: DCL\_DF23\_L2L3.asm

Declaration: float32\_t DCL\_runDF23\_L2(DCL\_DF23\_CLA \*p, float32\_t ek)

Description: This function computes the immediate part of the pre-computed DF23 controller. The function is identical in structure and operation to the C2 form. The function is coded in CLA assembly language.

Parameters: p                    The DCL\_DF23\_CLA structure  
               ek                    The servo error

Return:                    The control effort

**DCL\_runDF23\_L3**

**Run the Partial DF23 Compensator on the CLA**

Header File: DCLCLA.h

Source File: DCL\_DF23\_L2L3.asm

Declaration: float32\_t DCL\_runDF23\_L3(DCL\_DF23\_CLA \*p, float32\_t ek, float32\_t uk)

Description: This function computes the partial result of the pre-computed DF23 controller. The function is identical in structure and operation to the C3 form. The function is coded in CLA assembly language.

Parameters: p                    The DCL\_DF23\_CLA structure  
               ek                    The servo error  
               uk                    The control effort in the previous sample interval

Return:                    The control effort

**DCL\_resetDF23**

**Resets the DF23 Compensator**

Header File: DCLF32.h

Source File: N/A

Declaration: void DCL\_resetDF23(DCL\_DF23 \*p)

Description: This function resets the internal variables in the DCL\_DF23 structure to default values. The forward and return path coefficients are configured to implement a unity gain response, and the `err` field in the CSS sub-structure is set NONE. Note that the function is atomic.

Parameters: p                    The DCL\_DF23 structure

Return: Void

***DCL\_updateDF23******Updates the DF23 Compensator Parameters***

Header File: DCLF32.h

Source File: N/A

Declaration: void DCL\_updateDF23(DCL\_DF23 \*p)

Description: This function tests the `sts` field in the CSS sub-structure to determine whether a parameter update is required. If so, the parameters stored in the SPS sub-structure are copied into the DF23 structure and `sts` is cleared. Note that the function is atomic. Refer to section 2.4 for more information on updating controller parameters.

Parameters: p The DCL\_DF23 structure

Return: Void

***DCL\_fupdateDF23******Updates the DF23 Controller Parameters***

Header File: DCLF32.h

Source File: DCL\_futils.asm

Declaration: void DCL\_fupdateDF23(DCL\_DF23 \*p)

Description: This function tests the `sts` field in the CSS sub-structure to determine whether a parameter update is required. If so, the parameters stored in the SPS sub-structure are copied into the DF23 structure and `sts` is cleared. Note that the function is atomic. Refer to section 2.4 for more information on updating controller parameters. The function is implemented as an assembly module.

Parameters: p The DCL\_DF23 structure

Return: Void

***DCL\_isStableDF23******Determines whether the DF23 Compensator is Stable***

Header File: DCLF32.h

Source File: N/A

Declaration: int16\_t DCL\_isStableDF23(DCL\_DF23 \*p)

Description: This function determines whether the coefficient set in the SPS sub-structure represent a stable compensator. If the pole magnitude is less than one, the function returns '1', indicating stability; otherwise the function returns '0'. Refer to section 1.3.9 for more information on compensator stability tests.

Parameters: p The DCL\_DF23 structure

Return: '1' if stable, otherwise '0'

**DCL\_loadDF23asZPK**

**Loads the DF23 Compensator from ZPK**

Header File: DCLF32.h

Source File: N/A

Declaration: void DCL\_loadDF23asZPK(DCL\_DF23 \*p, DCL\_ZPK3 \*q)

Description: This function loads the DF23 compensator coefficients in the SPS sub-structure from a 3-pole, 3-zero description held in a ZPK3 structure. Active coefficients are unaffected until the `DCL_updateDF23()` function is called. Refer to section 1.3.8 for more information on the ZPK3 structure.

Parameters: p                    The DCL\_DF23 structure

                  q                    The DCL\_ZPK3 structure

Return: Void

## 3.10 Fixed-Point PID Controllers

### 3.10.1 Description

The DCL contains one implementation of a parallel form fixed-point PID controller. The structure is similar to the floating-point C1 controller. Refer to section 3.1 for more information.

### 3.10.2 Implementation

The linear PID controller in the DCL32 includes the following features.

- Parallel form
- Programmable output saturation
- Anti-windup integrator reset
- Programmable low-pass derivative filter
- Feedback input to derivative path

Both PID and PI type controllers in the DCI32 library implement integrator anti-windup reset in a similar way. A clamp is present at the controller output which allows the user to set upper and lower limits on the control effort. If either limit is exceeded, an internal floating-point controller variable changes from logical 1 to logical 0. This variable is converted into Q24 format and multiplied by the integrator input, such that the integrator accumulates successive zero data when the output is saturated, avoiding the “wind-up” phenomenon.

The following equations describe the implementation of the PID32 controller. Note that the storage of static variables  $\{i_{14} i_{10} d_2 d_3\}$  is not shown.

The servo error equation is

$$\text{Equation 26. } v_5(k) = r(k) - y(k)$$

The proportional path equation is

$$\text{Equation 27. } v_6(k) = K_p v_5(k)$$

The integral path equations are

$$\text{Equation 28. } v_7(k) = K_i v_5(k)$$

$$\text{Equation 29. } v_{14}(k) = v_{12}(k-1)v_7(k)$$

$$\text{Equation 30. } v_8(k) = v_{14}(k) + v_8(k-1)$$

The derivative path equations are

$$\text{Equation 31. } v_1(k) = K_d v_5(k)$$

$$\text{Equation 32. } v_2(k) = c_1 v_1(k)$$

$$\text{Equation 33. } v_4(k) = v_2(k) - v_2(k-1) - v_3(k-1)$$

$$\text{Equation 34. } v_3(k) = c_2 v_4(k)$$

Note that the derivative coefficient  $c_1$  must be divided by two on initialization. This element is typically much larger than  $c_2$  so we enter half its value in the code and multiply twice. This allows greater numerical range for a given Q-format.

The output path equations are

$$\text{Equation 35. } v_9(k) = v_6(k) + v_8(k) + v_4(k)$$

$$\text{Equation 36. } u(k) = \begin{cases} v_9(k) & : u_{\min} < v_9(k) < u_{\max} \\ u_{\max} & : v_9(k) \geq u_{\max} \\ u_{\min} & : v_9(k) \leq u_{\min} \end{cases}$$

$$\text{Equation 37. } v_{11}(k) = u(k) - v_9(k)$$

$$\text{Equation 38. } v_{12}(k) = \begin{cases} 1 & : v_{11}(k) = 0 \\ 0 & : v_{11}(k) \neq 0 \end{cases}$$

$$\text{Equation 39. } i_{14}(k) = v_{12}(k)$$

The DCL\_PID32 implementation is shown below:

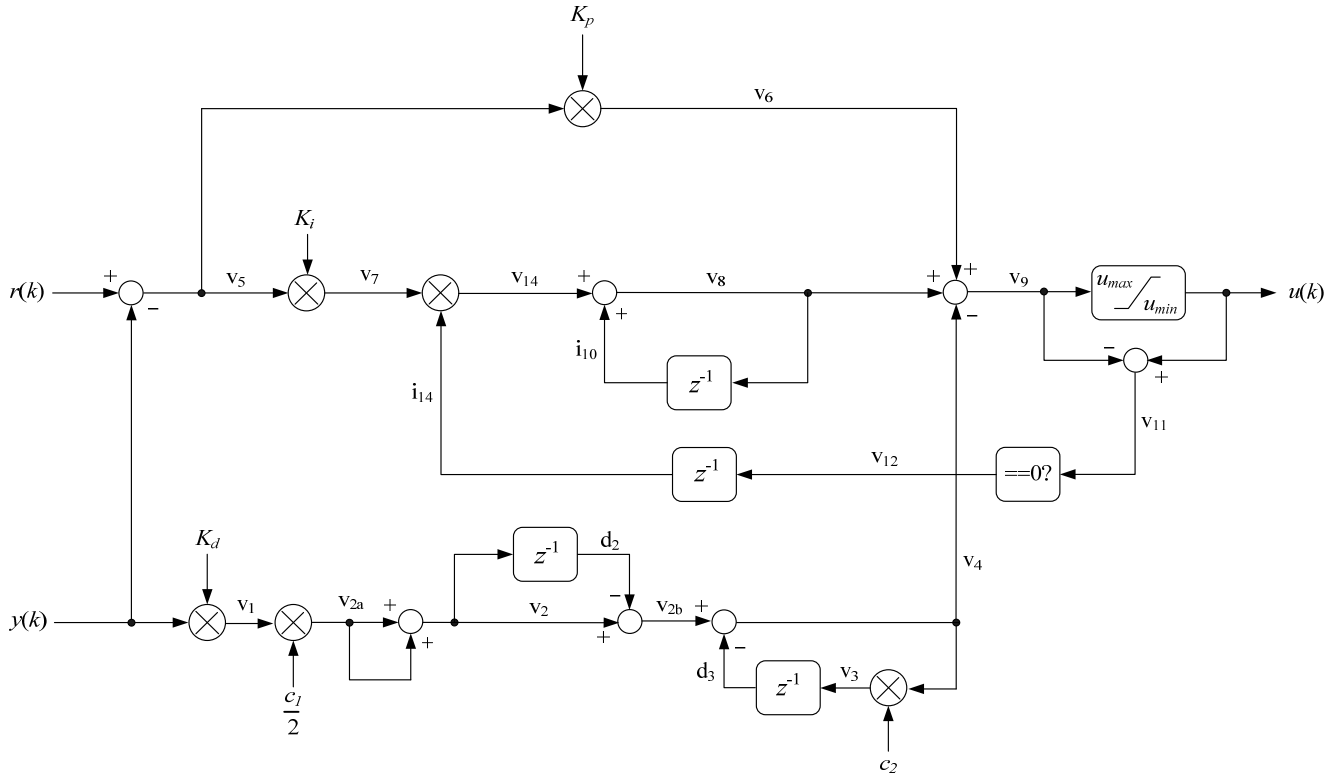

Figure 31. DCL\_PID32 A1 architecture

The linear PID\_A1 controller uses a C structure to hold coefficients and data, defined in the header file DCLC28.h. The order of these structure elements must not be changed by the user.

### 3.10.3 Functions

<b>DCL_runPID_A1</b>	<b>Run the Parallel Form PID32 Controller</b>
----------------------	---

- Header File: DCLC28.h
- Source File: DCL\_PID\_A1.asm
- Declaration: int32\_t DCL\_runPID\_A1(DCL\_PID32 \*p, int32\_t rk, int32\_t yk)
- Description: This function executes a parallel form PID controller on the C28x. The function is coded in C28x assembly. All input and output variables are in Q24 format.
- Parameters:
 

p	The PID32 structure
rk	The controller set-point reference
yk	The measured feedback
- Return: The control effort



**DCL\_resetPID32****Resets the PID Controller**

Header File: DCLC28.h

Source File: N/A

Declaration: void DCL\_resetPID32(DCL\_PID32 \*p)

Description: This function resets the internal variables in the DCL\_PID32 structure to default values. The integrator accumulator and store derivative path values are set to zero, and the integrator clamp variable set to one. The function also sets the `err` field in the CSS sub-structure is set NONE. Note that the function is atomic.

Parameters: p                    The DCL\_PID32 structure

Return: Void

**DCL\_updatePID32****Updates the PID32 Controller Parameters**

Header File: DCLC28.h

Source File: N/A

Declaration: void DCL\_updatePID32(DCL\_PID32 \*p)

Description: This function tests the `sts` field in the CSS sub-structure to determine whether a parameter update is required. If so, the parameters stored in the SPS sub-structure are copied into the PID structure and `sts` is cleared. Note that the function is atomic. Refer to section 2.4 for more information on updating controller parameters.

Parameters: p                    The DCL\_PID32 structure

Return: Void

**DCL\_fupdatePID32****Updates the PID32 Controller Parameters**

Header File: DCLC28.h

Source File: DCL\_futils32.asm

Declaration: void DCL\_fupdatePID32(DCL\_PID32 \*p)

Description: This function tests the `sts` field in the CSS sub-structure to determine whether a parameter update is required. If so, the parameters stored in the SPS sub-structure are copied into the PID32 structure and `sts` is cleared. This function is implemented as an assembly module and does not perform any error checking. Note that the function is atomic. Refer to section 2.4 for more information on updating controller parameters.

Parameters: p                    The DCL\_PID32 structure

Return: Void

### 3.11 Fixed-Point PI Controllers

#### 3.11.1 Description

The DCL contains one implementation of a fixed-point series form PI controller. The PI is similar in operation to the PID controller, with the removal of the derivative path. Refer to section 3.2 for more information.

#### 3.11.2 Implementation

The following equations describe the implementation of the PI32 controller.

$$\text{Equation 40. } v_1(k) = r(k) - y(k)$$

$$\text{Equation 41. } v_2(k) = K_p v_1(k)$$

$$\text{Equation 42. } v_3(k) = K_i v_2(k)$$

$$\text{Equation 43. } v_8(k) = v_3(k-1)v_3(k)$$

$$\text{Equation 44. } v_4(k) = v_8(k) + v_4(k-1)$$

$$\text{Equation 45. } v_5(k) = v_2(k) + v_4(k)$$

$$\text{Equation 46. } u(k) = \begin{cases} v_5(k) & : u_{\min} < v_5(k) < u_{\max} \\ u_{\max} & : v_5(k) \geq u_{\max} \\ u_{\min} & : v_5(k) \leq u_{\min} \end{cases}$$

$$\text{Equation 47. } v_7(k) = u(k) - v_5(k)$$

$$\text{Equation 48. } v_9(k) = \begin{cases} 1 & : v_7(k) = 0 \\ 0 & : v_7(k) \neq 0 \end{cases}$$

The ideal form PI implementation is shown below:

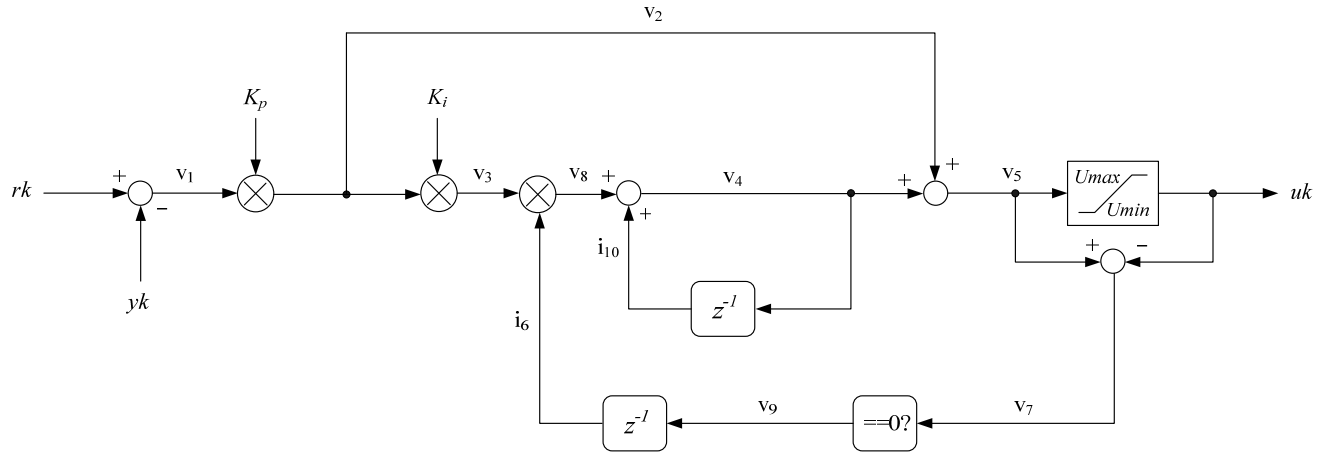

Figure 32. DCL\_PI A1 architecture

The linear PI controller uses a C structure to hold coefficients and data, defined in the header file DCLC28.h. The order of these structure elements must not be changed by the user.

### 3.11.3 Functions

<b>DCL_runPI_A1</b>	<b>Run the Ideal Form PI32 Controller</b>
---------------------	---

Header File: DCLC28.h

Source File: DCL\_PI\_A1.asm

Declaration: int32\_t DCL\_runPI\_A1(DCL\_PI32 \*p, int32\_t rk, int32\_t yk)

Description: This function executes an ideal form PI32 controller on the C28x. The function is coded in C28x assembly. All input and output variables are in Q24 format.

Parameters:

p	The PI32 structure
rk	The controller set-point reference
yk	The measured feedback

Return: The control effort

<b>DCL_resetPI32</b>	<b>Resets the PI Controller</b>
----------------------	---------------------------------

Header File: DCLC28.h

Source File: N/A

Declaration: void DCL\_resetPI32(DCL\_PI32 \*p)

Description: This function resets the internal variables in the DCL\_PI32 structure to default values. The integrator accumulator and store derivative path values are set to

zero, and the integrator clamp variable set to one. The function also sets the `err` field in the CSS sub-structure is set NONE. Note that the function is atomic.

Parameters: `p`                    The DCL\_PI32 structure  
 Return:            Void

<b>DCL_updatePI32</b>	<b>Updates the PI32 Controller Parameters</b>
-----------------------	---

Header File:    DCLC28.h  
 Source File:    N/A  
 Declaration:    void DCL\_updatePI32(DCL\_PI32 \*p)  
 Description:    This function tests the `sts` field in the CSS sub-structure to determine whether a parameter update is required. If so, the parameters stored in the SPS sub-structure are copied into the PID structure and `sts` is cleared. Note that the function is atomic. Refer to section 2.4 for more information on updating controller parameters.  
 Parameters:    `p`                    The DCL\_PI32 structure  
 Return:            Void

<b>DCL_fupdatePI32</b>	<b>Updates the PI32 Controller Parameters</b>
------------------------	---

Header File:    DCLC28.h  
 Source File:    DCL\_futils32.asm  
 Declaration:    void DCL\_fupdatePI32(DCL\_PI32 \*p)  
 Description:    This function tests the `sts` field in the CSS sub-structure to determine whether a parameter update is required. If so, the parameters stored in the SPS sub-structure are copied into the PI32 structure and `sts` is cleared. This function is implemented as an assembly module and does not perform any error checking. Note that the function is atomic. Refer to section 2.4 for more information on updating controller parameters.  
 Parameters:    `p`                    The DCL\_PI32 structure  
 Return:            Void

### 3.12 Gain Scheduler Module

#### 3.12.1 Description

The DCL contains an implementation of a basic Gain Scheduler Module (GSM) which runs on the FPU32. The GSM works by dividing the positive normalized input range, from

0 to +1, into eight equal sectors, each of which is associated with a separate gain. The negative input range, from 0 to -1, has the same gains but with a sign change.

As the input sweeps through the full range from -1 to +1, the output changes in a way determined by the entries in two look-up tables loaded by the user. One table fixes the gain in each sector, while the other fixes the offsets at the sector boundaries. In this way, the user may realize a piecewise continuous non-linear input-output function without introducing step discontinuities into the control.

### 3.12.2 Implementation

The sector gain look-up table consists of eight entries covering the normalized positive input range. The sector offset table consists of nine entries, with the first entry set to zero, and the final entry defining the output when the input is equal to 1. Figure 33 shows the sector numbering used in the GSM for a typical target curve. Sectors, gains, and offsets are denoted  $S$ ,  $m$ , and  $c$  respectively. Note the symmetry for positive and negative inputs, and the clamp characteristic on the upper right when the input magnitude exceeds 1.

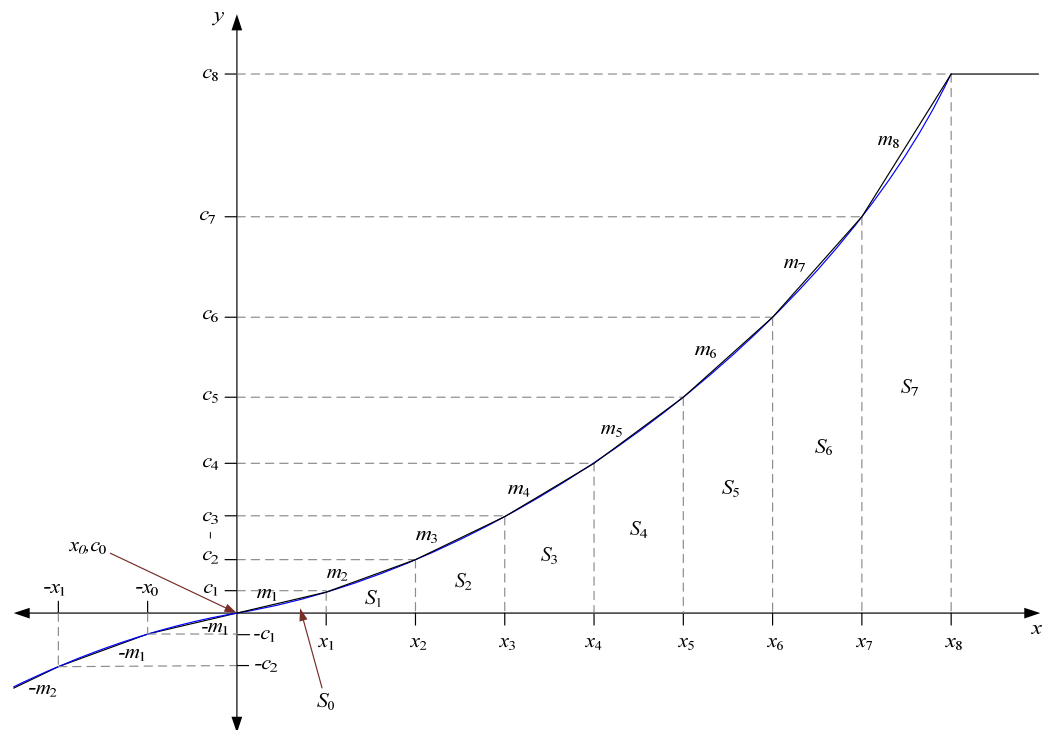

Figure 33.

#### *DCL\_GSM sector numbering*

A typical scenario is that the user will identify a target function from which the GSM curve will be loaded. The user will load each of the nine offsets in the SPS sub-structure from the target function, then call the function `DCL_loadGSMgains()` to initialize the gain table. Once this is done, the SPS tables can be copied into the active parameter set using the `DCL_updateGSM()` function. Refer to code example 7 in chapter 5 to see how this might be done.

The Matlab script file `GSM_example.m` can be found in the `\models` sub-directory and demonstrates how the gain and offset tables are initialized. Note that due to array

indexing differences between Matlab and C, sector initialization is slightly different to the DCL code.

### 3.12.3 Functions

<b>DCL_runGSM_C1</b>	<b>Run the Gain Scheduler Module</b>
----------------------	--------------------------------------

Header File: DCLF32.h

Source File: N/A

Declaration: float32\_t DCL\_runGSM\_C1(DCL\_GSM \*p, float32\_t x)

Description: This function runs the gain scheduler to determine an output from the gain and offset arrays in the DCL\_GSM structure. The function is coded in in-line C.

Parameters: p                    The DCL\_GSM structure  
                   x                    The normalized input

Return:                    The gain adjusted output

<b>DCL_resetGSM</b>	<b>Resets the GSM Module</b>
---------------------	------------------------------

Header File: DCLF32.h

Source File: N/A

Declaration: void DCL\_resetGSM(DCL\_GSM \*p)

Description: This function resets the internal variables in the DCL\_GSM structure to default values. All gain segments are set to unity gain and the offset array configured to generate a linear input/output relationship. The function also sets the `err` field in the CSS sub-structure set NONE. Note that the function is atomic.

Parameters: p                    The DCL\_GSM structure

Return:                    Void

<b>DCL_updateGSM</b>	<b>Updates the GSM Parameters</b>
----------------------	-----------------------------------

Header File: DCLF32.h

Source File: N/A

Declaration: void DCL\_updateGSM(DCL\_GSM \*p)

Description: This function tests the `sts` field in the CSS sub-structure to determine whether a parameter update is required. If so, the parameters stored in the SPS sub-structure are copied into the active DCL\_GSM structure and `sts` is cleared. Note

that the function is atomic. Refer to section 2.4 for more information on updating controller parameters.

Parameters: p                    The DCL\_GSM structure  
 Return:        Void

<b><i>DCL_fupdateGSM</i></b>	<b><i>Updates the GSM Controller Parameters</i></b>
------------------------------	---

Header File:    DCLF32.h  
 Source File:    DCL\_futils.asm  
 Declaration:    void DCL\_fupdateGSM(DCL\_GSM \*p)  
 Description:    This function tests the `sts` field in the CSS sub-structure to determine whether a parameter update is required. If so, the parameters stored in the SPS sub-structure are copied into the GSM structure and `sts` is cleared. Note that the function is atomic. Refer to section 2.4 for more information on updating controller parameters. The function is implemented as an assembly module.  
 Parameters:    p                    The DCL\_GSM structure  
 Return:        Void

<b><i>DCL_loadGSMoffsets</i></b>	<b><i>Loads the GSM Offset Parameters</i></b>
----------------------------------	---

Header File:    DCLF32.h  
 Source File:    N/A  
 Declaration:    void DCL\_loadGSMoffsets(DCL\_GSM \*p)  
 Description:    This function configures the offset array in the SPS sub-structure to produce a piecewise continuous input-output curve from the gains. The active parameters are not affected until the `DCL_updateGSM()` function is called.  
 Parameters:    p                    The DCL\_GSM structure  
 Return:        Void

<b><i>DCL_loadGSMgains</i></b>	<b><i>Loads the GSM Gain Parameters</i></b>
--------------------------------	---

Header File:    DCLF32.h  
 Source File:    N/A  
 Declaration:    void DCL\_loadGSMgains(DCL\_GSM \*p)  
 Description:    This function configures the gain array in the SPS sub-structure to produce a piecewise continuous input-output curve from the offsets. The active parameters are not affected until the `DCL_updateGSM()` function is called.

Parameters: p                    The DCL\_GSM structure  
 Return:            Void

### 3.13 Non-linear Control Law

#### 3.13.1 Description

The DCL contains an implementation of the non-linear control law used in the NLPID & NLPI controller described earlier in this section. The user could apply this function to implement a gain scheduling type of control.

#### 3.13.2 Implementation

Refer to section 3.3.1 for information on the non-linear law.

#### 3.13.3 Functions

<b>DCL_runNLF_C1</b>	<b>Run the NLF Control Law</b>
----------------------	--------------------------------

Header File: DCL\_NLPID.h  
 Source File: N/A  
 Declaration: float32\_t DCL\_runNLF\_C1(float32\_t x, float32\_t alpha, float32\_t delta)  
 Description: This function executes a non-linear control law defined by the parameters in the DCL\_NLF structure. No error checks are performed on the parameters. The function is coded in inline C.  
 Parameters: x            The input variable  
               alpha        The non-linear exponent  
               delta        The linear region semi-width  
 Return:            The non-linear result

### 3.14 Double Precision PID Controllers

#### 3.14.1 Description

The DCL contains one implementation of a linear PID controller in double precision floating point form. This controller may be used with the FPU32 CPU, however support for the double precision data type currently relies on the run time support libraries which are not cycle efficient. The structure of the controller is identical to the PID\_C1 & PID\_C2 controllers described earlier in this chapter. Support functions for PIDF64 do not currently include the ability to load the controller from transfer function coefficient or ZPK3 descriptions.



### 3.14.2 Implementation

The controller is supplied in inline C source. Refer to section 3.1.2 for further information.

### 3.14.3 Functions

<b>DCL_runPIDF64_S1</b>	<b>Run the PIDF64 Controller</b>
-------------------------	----------------------------------

Header File: DCLF64.h

Source File: N/A

Declaration: float64\_t DCL\_runPIDF64\_S1(DCL\_PIDF64 \*p, float64\_t rk, float64\_t yk, float32\_t lk)

Description: This function executes an ideal form PIDF64 controller on the FPU32, and is identical in structure and operation to the C1 & C2 forms. The function is coded in inline C.

Parameters:

p	The DCL_PIDF64 structure
rk	The controller set-point reference
yk	The measured feedback
lk	External output clamp flag

Return: The control effort

<b>DCL_resetPIDF64</b>	<b>Resets the PIDF64 Controller</b>
------------------------	-------------------------------------

Header File: DCLF64.h

Source File: N/A

Declaration: void DCL\_resetPIDF64(DCL\_PIDF64 \*p)

Description: This function resets the internal variables in the DCL\_PIDF64 structure to default values. The integrator accumulator and store derivative path values are set to 0.0, and the integrator clamp variable set to 1.0. The function also sets the `err` field in the CSS sub-structure to NONE. Note that the function is atomic.

Parameters:

p	The DCL_PIDF64 structure
---	--------------------------

Return: Void

<b>DCL_updatePIDF64</b>	<b>Updates the PIDF64 Controller Parameters</b>
-------------------------	---

Header File: DCLF64.h

Source File: N/A

Declaration: void DCL\_updatePIDF64(DCL\_PIDF64 \*p)

Description: This function tests the `sts` field in the CSS sub-structure to determine whether a parameter update is required. If so, the parameters stored in the SPS sub-structure are copied into the PIDF64 structure and `sts` is cleared. Note that the function is atomic. Refer to section 2.4 for more information on updating controller parameters.

Parameters: `p` The DCL\_PIDF64 structure

Return: Void

**DCL\_setPIDF64filterBW**

**Set the PIDF64 Derivative Filter Bandwidth**

Header File: DCLF64.h

Source File: N/A

Declaration: `void DCL_setPIDF64filterBW(DCL_PIDF64 *p, float64_t fc)`

Description: Loads the derivative filter coefficients `c1` & `c2` in the SPS based on the desired filter bandwidth specified in Hz. Coefficients in the active parameter set are unaffected until the controller is updated using `DCL_updatePIDF64()`.

Parameters: `p` The DCL\_PIDF64 structure

`fc` The desired filter bandwidth in Hz

Return: Void

**DCL\_setActivePIDF64filterBW**

**Set the Active PIDF64 Derivative Filter Bandwidth**

Header File: DCLF64.h

Source File: N/A

Declaration: `void DCL_setActivePIDF64filterBW(DCL_PIDF64 *p, float64_t fc, float64_t T)`

Description: Loads the derivative filter coefficients `c1` & `c2` in the active PIDF64 structure based on the desired filter bandwidth specified in Hz and the controller update rate in seconds. This function does not use or modify the SPS.

Parameters: `p` The DCL\_PIDF64 structure

`fc` The desired filter bandwidth in Hz

`T` The controller update rate in seconds

Return: Void

**DCL\_getPIDF64filterBW**

**Get the PIDF64 Derivative Filter Bandwidth**

Header File: DCLF64.h

Source File: N/A

Declaration: float64\_t DCL\_getPIDF64filterBW(DCL\_PIDF64 \*p)

Description: Finds the bandwidth of the current derivative filter in Hz by examining the coefficients in the active parameter set (i.e. not the SPS).

Parameters: p                    The DCL\_PIDF64 structure

Return:                    The active derivative filter bandwidth in Hz

### 3.15 Double Precision DF22 Compensators

#### 3.15.1 Description

From version 3.4, the DCL contains support for the DF22 compensator in double precision floating point. The controller architecture is identical to that described in section 3.8 so the details need not be repeated here. One full controller and a pair of functions to support a pre-computed controller are implemented. There are also 'reset' and 'update' functions, and a double precision clamp function (see section 4.1). Other single precision functions to support coefficient calculation are not implemented at this time.

#### 3.15.2 Implementation

The controller is supplied in inline C source. Refer to section 3.1.2 for further information.

#### 3.15.3 Functions

<b>DCL_runDF22F64_S1</b>	<b>Run the DF22F64 Controller</b>
--------------------------	-----------------------------------

Header File: DCLF64.h

Source File: N/A

Declaration: float64\_t DCL\_runDF22F64\_S1(DCL\_DF22F64 \*p, float64\_t ek)

Description: This function executes a full DF22 compensator on the FPU64

Parameters: p                    The DCL\_DF22F64 structure  
               ek                    The input error

Return:                    The control effort

<b>DCL_runDF22F64_S2</b>	<b>Run the Immediate DF22F64 Compensator</b>
--------------------------	--

Header File: DCLF64.h

Source File: N/A

Declaration: float64\_t DCL\_runDF22F64\_S2(DCL\_DF22F64 \*p, float64\_t ek)  
 Description: This function computes the immediate part of the pre-computed DF22 controller.  
 Parameters: p The DCL\_DF22F64 structure  
 ek The servo error  
 Return: The control effort

**DCL\_runDF22F64\_S3**

**Run the Partial DF22F64 Compensator**

Header File: DCLF64.h  
 Source File: N/A  
 Declaration: void DCL\_runDF22F64\_S3(DCL\_DF22F64 \*p, float64\_t ek, float64\_t uk)  
 Description: This function computes the partial result of the pre-computed DF22F64 controller.  
 Parameters: p The DCL\_DF22F64 structure  
 ek The servo error  
 uk The control effort in the previous sample interval  
 Return: The control effort

**DCL\_resetDF22F64**

**Resets the DF22F64 Controller**

Header File: DCLF64.h  
 Source File: N/A  
 Declaration: void DCL\_resetDF22F64(DCL\_DF22F64 \*p)  
 Description: This function resets the internal variables in the DCL\_DF22F64 structure to default values. Note that the function is atomic.  
 Parameters: p The DCL\_DF22F64 structure  
 Return: Void

**DCL\_updateDF22F64**

**Updates the DF22F64 Controller Parameters**

Header File: DCLF64.h  
 Source File: N/A  
 Declaration: void DCL\_updateDF22F64(DCL\_DF22F64 \*p)  
 Description: This function tests the `sts` field in the CSS sub-structure to determine whether a parameter update is required. If so, the parameters stored in the SPS sub-

structure are copied into the DF22F64 structure and `sts` is cleared. Note that the function is atomic. Refer to section 2.4 for more information on updating controller parameters.

Parameters: `p`                    The DCL\_DF22F64 structure

Return:            Void

---

---

# Utilities

---

---

This chapter describes the supporting functions included in the Digital Control Library.

## Section

- 4.1 Control Clamps**
- 4.2 Floating Point Data Logging Functions**
- 4.3 4-channel Floating Point Data Logger**
- 4.4 Transient Capture Module**
- 4.5 Performance Measurement**
- 4.6 Fixed Point Data Logging Functions**

The Digital Controller Library includes a small number of utilities intended to support use of the library. These include:

- Clamp functions for the CPU and CLA
- Floating point data logging functions
- A 4-channel floating point data logger
- A Transient Capture Module
- Functions for measurement of control performance
- Fixed point data logging functions
- A 4-channel fixed point data logger
- A reference generator

The reference generator module is documented in a separate user's guide which can be found in the \docs sub-directory of the DCL installation path.

## 4.1 Control Clamps

### 4.1.1 Description

The library contains three functions for clamping a control variable to specified upper and lower limits. These would typically be used to impose a pre-defined bound the output of a

controller function to prevent actuator saturation or overload. Saturation in a control loop must be handled with care since control of the system is effectively lost. Furthermore, controllers which implement integration of historical servo data can exhibit a phenomenon known as “wind-up”, in which the controller output increases in magnitude while the loop is saturated. This condition leads to delay in recovering from the saturation because the accumulated controller output must be removed before it comes within range of the actuator and the controller resumes proper operation. For more information on integrator wind-up, refer to section 3.1.1 and ref. [3].

The clamp functions bound the input data variable to pre-determined limits and return a logical value 1 if either bound is matched or exceeded. If the input data lies definitely within limits (i.e. neither bound is matched or exceeded) the functions return logical 0. The return value can be used by PI & PID regulators to implement anti-windup reset, and may be used to clamp the output of the pre-computed forms of all direct form compensators. An example may be found in the DF22 example project supplied with the library (see chapter 5).

A difference exists between the C28x clamp function and that of the CLA. On the CPU the returned value is an unsigned integer of either 0 or 1, while the corresponding CLA function returns a floating point value of 0.0f or 1.0f. This is because the handling of fixed-point data on the CLA is less efficiently supported than on the main CPU.

#### 4.1.2 Functions

##### ***DCL\_runClamp\_C1***

##### ***Floating-Point Data Clamp***

Header File: DCLF32.h

Source File: DCL\_clamp\_C1.asm

Declaration: int16\_t DCL\_runClamp\_C1(float \*data, float Umax, float Umin)

Description: This function clamps a floating-point data value to defined limits and returns a non-zero integer if either limit is matched or exceeded. The input data is modified by the function. The function is coded in assembly.

Parameters: data            Pointer to the input data

Umax            The upper data limit

Umin            The lower data limit

Return: 0 if the data lies definitely within limits, 1 if the data matches or exceeds the limits.

##### ***DCL\_runClamp\_C2***

##### ***Floating-Point Data Clamp***

Header File: DCLF32.h

Source File: N/A

Declaration: int16\_t DCL\_runClamp\_C2(float \*data, float Umax, float Umin)

Description: This function clamps a floating-point data value to defined limits and returns a non-zero integer if either limit is matched or exceeded. The input data is modified by the function. The function is coded in inline C.

Parameters: data            Pointer to the input data  
 Umax            The upper data limit  
 Umin            The lower data limit

Return: 0 if the data lies definitely within the specified limits; 1 if the data matches or exceeds the specified limits.

**DCL\_runClamp\_L1****Floating-Point Data Clamp**

Header File: DCLCLA.h

Source File: DCL\_clamp\_L1.asm

Declaration: float DCL\_runClamp\_L1(float \*data, float Umax, float Umin)

Description: This function clamps a floating-point data value to defined limits and returns a non-zero floating-point result if either limit is matched or exceeded. The function is coded in CLA assembly.

Parameters: data            The input data  
 Umax            The upper data limit  
 Umin            The lower data limit

Return: 0.0f if the data lies definitely within the specified limits; 1.0f if the data matches or exceeds the specified limits.

**DCL\_runClamp\_S1****Floating-Point Data Clamp**

Header File: DCLF64.h

Source File: N/A

Declaration: int16\_t DCL\_runClamp\_S1(float64\_t \*data, float64\_t Umax, float64\_t Umin)

Description: This function clamps a double precision floating-point data value to defined limits and returns a non-zero integer if either limit is matched or exceeded.

Parameters: data            The input data  
 Umax            The upper data limit  
 Umin            The lower data limit

Return: 0 if the data lies definitely within the specified limits; 1 if the data matches or exceeds the specified limits.



## 4.2 Floating Point Data Logging Functions

### 4.2.1 Description

The Digital Control Library includes a general purpose floating-point data logger utility which is useful when testing and debugging control applications. The intended use of the data logger utility is to capture a stream of data values in a block of memory for subsequent analysis. The data logger is supplied in the form of a C header file and one assembly file, and it may be used on any C2000 device irrespective of whether the DCL is used. The utility may not be used on the CLA.

The data logger operates with arrays of 32-bit floating-point data. The location, size, and indexing of each array are defined by three pointers capturing the start address, end address, and data index address. All three pointers are held in a common C structure with the data type "FDLOG", defined as follows:

```
typedef volatile struct {
    float *fptr;
    float *lptr;
    float *dptr;
} FDLOG;
```

Conceptually, the relationship between the array pointers and the elements of a data array of length "N" is shown below:

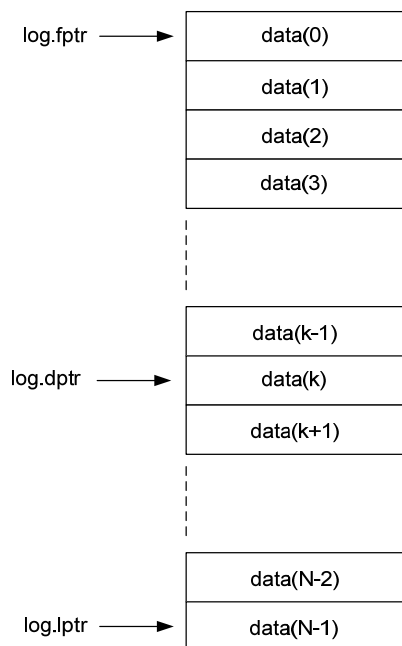

Figure 34.

#### Data log pointer allocation

The data index pointer (dptr) always points to the next address to be written or read, and advances through the memory block as each new data value is written into the log. On reaching the end of the log, the pointer is reset to the first address in the log. The data logger header file contains a set of in-line C functions to access and manipulate data logs.

To use the data logger, you must include the header file `DCL_fdlog.h` in your project. Typically, a user would create an instance of an FDLOG structure as follows:

```
FDLOG myBuf = FDLOG_DEFAULTS;
```

The log pointers can then be initialized in the user's code such that they reference a memory block in a specific address range. Thereafter, the code can clear or load the buffer a specific data value, and then begin writing data into it using the `DCL_writeLog()` function. The DF22 example project shows how this is done.

The DCL also contains two functions which perform fast read and write to a data log. These are assembly coded functions in the source file `DCL_frwlog.asm`. The execution cycles for these and the corresponding C coded DCL functions are shown below:

**Table 13.** *Data log read/write benchmarks*

DCL_writeLog	48
DCL_readLog	39
DCL_fwriteLog	22
DCL_freadLog	22

#### 4.2.2 Functions

##### ***DCL\_deleteLog***

##### ***Delete a Data Log***

Header File: `DCL_fdlog.h`

Source File: N/A

Declaration: `void DCL_deleteLog(FDLOG *p)`

Description: This function resets all structure pointers to null value.

Parameters: `p`                    The FDLOG structure

Return: Void

##### ***DCL\_resetLog***

##### ***Reset a Data Log***

Header File: `DCL_fdlog.h`

Source File: N/A

Declaration: `void DCL_resetLog(FDLOG *p)`

Description: This function resets the data index pointer to start of the data log.

Parameters: `p`                    The FDLOG structure

Return: Void

**DCL\_initLog****Initialize a Data Log Structure**

Header File:	DCL_fdlog.h	
Source File:	N/A	
Declaration:	void DCL_initLog(FDLOG *p, float32_t *addr, uint16_t size)	
Description:	This function assigns the buffer pointers to a memory block or array and sets the data index pointer to the first address.	
Parameters:	p	The FDLOG structure
	addr	The start address of the memory block
	size	The length of the memory block in 32-bit words
Return:	Void	

**DCL\_writeLog****Write Data into a Log**

Header File:	DCL_fdlog.h	
Source File:	N/A	
Declaration:	float DCL_writeLog(FDLOG *p, float32_t data)	
Description:	This function writes a data point into the buffer and advances the indexing pointer, wrapping if necessary. The function returns the data value being over-written, which allows simple implementation of a fixed-length delay line.	
Parameters:	p	The FDLOG structure
	data	The input data value
Return:	The over-written data value	

**DCL\_fillLog****Fill a Data Log with Specified Data**

Header File:	DCL_fdlog.h	
Source File:	N/A	
Declaration:	void DCL_fillLog(FDLOG *p, float32_t data)	
Description:	This function fills the data log with a given data value and resets the data index pointer to the start of the log.	
Parameters:	p	The FDLOG structure
	data	The fill data value

Return: Void

**DCL\_clearLog****Fill a Data Log Contents with Zero**

Header File: DCL\_fdlog.h

Source File: N/A

Declaration: void DCL\_clearLog(FDLOG \*p)

Description: This function clears the buffer contents by writing 0 to all elements and resets the data index pointer to the start of the log.

Parameters: p The FDLOG structure

Return: Void

**DCL\_readLog****Fill a Data Log Contents with Zero**

Header File: DCL\_fdlog.h

Source File: N/A

Declaration: float32\_t DCL\_readLog(FDLOG \*p)

Description: This function reads a data point from the buffer and then advanced the index pointer, wrapping if necessary.

Parameters: p The FDLOG structure

Return: The indexed data value

**DCL\_copyLog****Copies one Data Log into Another**

Header File: DCL\_fdlog.h

Source File: N/A

Declaration: void DCL\_copyLog(FDLOG \*p, FDLOG \*q)

Description: This function copies the contents of one log into another and resets both buffer index pointers. The function assumes both logs have the same length.

Parameters: p The destination FDLOG structure

q The source FDLOG structure

Return: Void

**DCL\_freadLog****Performs Fast Read from a Data Log**

Header File:	DCL_fdlog.h
Source File:	DCL_frwwlog.asm
Declaration:	float32_t DCL_freadLog(FDLOG *p)
Description:	This function reads a data point from the log and then advances the indexing pointer, wrapping if necessary. This function is coded in assembly.
Parameters:	p                      The FDLOG structure
Return:	The indexed data value

**DCL\_fwriteLog****Performs Fast Write into a Data Log**

Header File:	DCL_fdlog.h
Source File:	DCL_frwwlog.asm
Declaration:	float32_t DCL_fwriteLog(FDLOG *p, float32_t data)
Description:	This function writes a data point into the buffer and advances the indexing pointer, wrapping if necessary. Returns the over-written data value for delay line or FIFO implementation. This function is coded in assembly.
Parameters:	p                      The FDLOG structure
	data                    The input data value
Return:	The over-written data value

### 4.3 4-channel Floating Point Data Logger

#### 4.3.1 Description

The Digital Control Library contains a 4 channel floating point data logger module denoted "MLOG". This module uses the data logger functions described above to capture up to four channels of incoming data in separate buffers for later inspection. The MLOG module is triggered by a sample at its first input exceeding either of a pair of user defined thresholds, after which incoming samples are successively logged into each buffer until they are full. A useful feature of the MLOG module is that the sampling rate can be adjusted by the user to change the time scale of the capture frame.

Conceptually, the MLOG architecture consists of four floating point data capture frames, each of which is a buffer defined by an FDLOG structure. The input to each buffer passes through a sample scaler, which divides the sample rate by a user programmable integer. Sampling is initiated when data at the first input exceeds a pre-defined upper or lower limit, after which the four data samples are logged into the capture frames at the desired rate until the buffers are full.

Note that the MLOG modules will be removed in version 4.0 of the DCL.

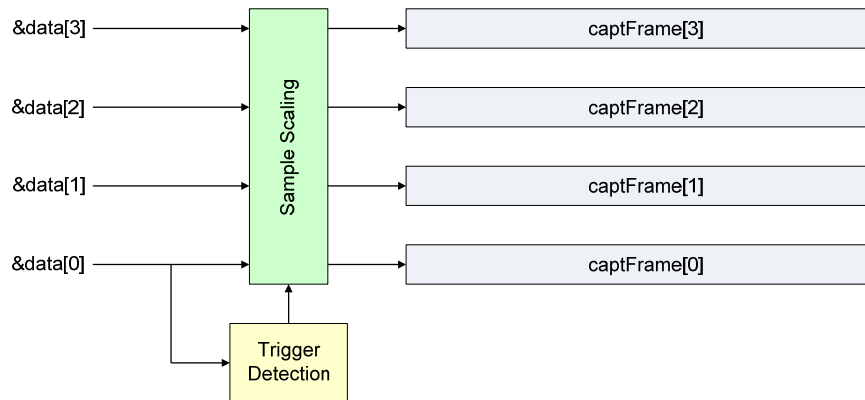

Figure 35. MLOG architecture

The MLOG module always operates in one of five modes:

- *MLOG\_idle*
- *MLOG\_armed*
- *MLOG\_capture*
- *MLOG\_complete*

The operating mode is stored in an element in the MLOG structure. All floating point MLOG functions are coded in inline C functions in the header file `MLOG.h`. Note that the DCL includes a separate fixed point 4-channel data logger which is described later in this chapter.

The MLOG module is defined by a C structure as follows:

```
typedef volatile struct {
    FDLOG captFrame[MLOG_CHANS];    //!< Capture data frames
    float32_t *data[MLOG_CHANS];    //!< Data channel pointers
    float32_t trigMax;               //!< Upper trigger threshold
    float32_t trigMin;              //!< Lower trigger threshold
    uint16_t tScale;                 //!< Number of samples/write
    uint16_t sCount;                 //!< Sample counter
    uint16_t mode;                   //!< Operating mode
} MLOG;
```

### 4.3.2 Functions

**DCL\_initMLOG**

**Initialize the MLOG Module**

Header File: `DCL_MLOG.h`

Source File: `N/A`

Declaration: `void DCL_initMLOG(MLOG *q, float32_t *addr, uint16_t size, float32_t tmax, float32_t tmin, uint16_t div)`

**Description:** This function loads all buffer contents with zero, and resets all buffer data pointers to their respective start addresses. The upper and lower trigger thresholds, and sample time scale are loaded into the MLOG structure. On completion, the MLOG module is in *MLOG\_idle* mode. The MLOG module will be removed in v4.0 of the library.

**Parameters:**

q	The MLOG structure
addr	Pointer to the start address of the MLOG buffers
size	The size in 32-bit words of each buffer
tmax	The upper trigger threshold
tmin	The lower trigger threshold
div	The sample scaler

**Return:** Void

### **DCL\_resetMLOG**

### **Reset the MLOG Module**

**Header File:** DCL\_MLOG.h

**Source File:** N/A

**Declaration:** void DCL\_resetMLOG(MLOG \*q)

**Description:** This function loads all buffer contents with zero, and resets all buffer data pointers to their respective start addresses. On completion, the MLOG module is in *MLOG\_idle* mode. The MLOG module will be removed in v4.0 of the library.

**Parameters:** q                    The MLOG structure

**Return:** Void

### **DCL\_armMLOG**

### **Arm the MLOG Module**

**Header File:** DCL\_MLOG.h

**Source File:** N/A

**Declaration:** void DCL\_armMLOG(MLOG \*q)

**Description:** This function changes the MLOG operating mode from *MLOG\_idle* to *MLOG\_armed*. If the operating mode is not already *MLOG\_idle* when the function is called, it sets the mode to *MLOG\_idle*. The MLOG module will be removed in v4.0 of the library.

**Parameters:** q                    The MLOG structure

**Return:** Void

Header File:	DCL_MLOG.h
Source File:	N/A
Declaration:	void DCL_runMLOG(MLOG *p)
Description:	This function runs the MLOG module. If in the <i>MLOG_armed</i> mode, the MLOG monitors its first input to determine whether either threshold has been exceeded. If so, the module enter <i>MLOG_capture</i> mode and sample collection begins. When the buffers are full, the operating mode is set to <i>MLOG_complete</i> . The MLOG module will be removed in v4.0 of the library.
Parameters:	q                      The MLOG structure
Return:	Void

#### 4.4 Transient Capture Module

The Transient Capture Module (TCM) is a triggered data logger which captures a burst of incoming data. A typical use is the capture of a transient response following a step input to a control system. The trigger conditions are a pair of user defined limits on the incoming data. The capture process is triggered by the first data point which exceeds either limit.

A feature of the TCM is that it captures a programmable length lead frame, allowing the user to inspect conditions immediately prior to the trigger condition. This is accomplished with three FDLOG structures which are elements in the TCM data structure, together with the limit pair. Once initialized, the status of the TCM is captured in one of four enumerated operating modes:

- *TCM\_idle*
- *TCM\_armed*
- *TCM\_capture*
- *TCM\_complete*

The TCM data is contained in a C structure as shown below:

```
typedef volatile struct {
    FDLOG moniFrame;    //!< Monitor data frame
    FDLOG leadFrame;   //!< Lead data frame
    FDLOG captFrame;   //!< Capture data frame
    float trigMax;     //!< Upper trigger threshold
    float trigMin;     //!< Lower trigger threshold
    uint16_t mode;     //!< Operating mode
    uint16_t lead;     //!< Lead frame size in 32-bit words
} TCM;
```

The current mode is available in the mode element in the TCM structure. To use the TCM, the user must do the following:



1. Include the header file `TCM.h` in the project.
2. Allocate a RAM memory block to hold the full capture buffer.
3. Create an instance of the TCM structure and initialize it using `DCL_initTCM()`
4. Arm the TCM using `DCL_armTCM()`
5. Log data into the TCM using `DCL_runTCM()`
6. Monitor the mode element in the TCM structure to determine when the capture is complete.

A code example illustrating the use of the TCM is supplied with the library and is described in chapter 5.

In the following diagrams, lead, capture, and monitor frames are indexed using the FDLOG structures `x`, `y`, & `z` respectively (note that these are not the names used in the TCM structure). FDLOG pointers are color coded blue, green, and red, respectively. To help visualize the sequence of events, the diagram shows in light gray the data which will eventually be logged into the TCM, and in blue the current frame contents in each mode.

#### 4.4.1 TCM\_idle Mode

In *TCM\_idle* mode the TCM buffers are as shown below. All buffer contents are zero, all frame data pointers are at the start of their respective frames and no data is being logged. This is the condition after the `DCL_initTCM()` function has been called.

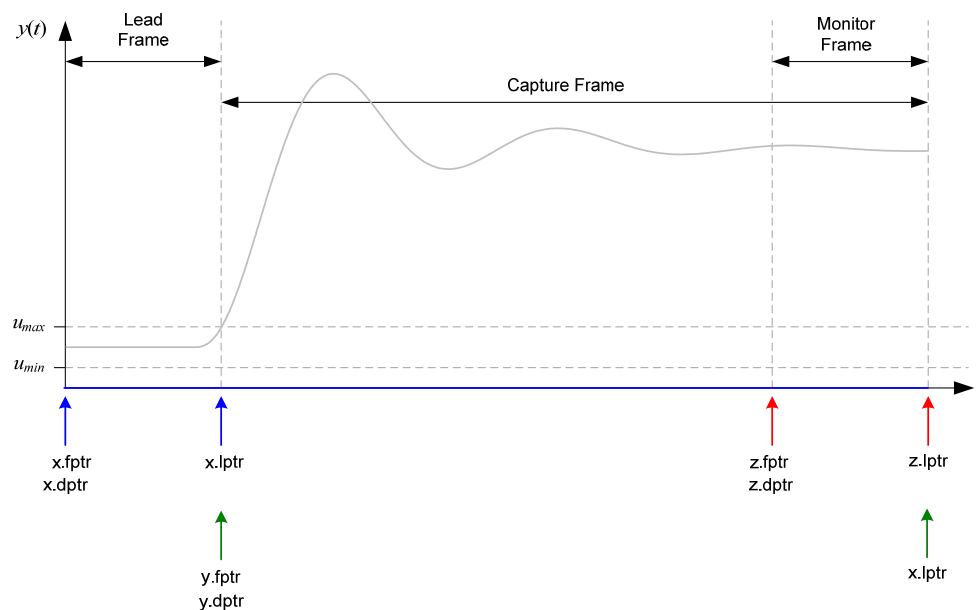

Figure 36. TCM operation in *TCM\_idle* mode

#### 4.4.2 TCM\_armed Mode

The TCM is armed by a call to `DCL_armTCM()`. In this mode, incoming data is continually logged in the monitor frame. The monitor frame acts as a circular buffer, the index pointer wrapping to the start of the monitor frame when it reaches the end.

Each data point is compared with the upper and lower trigger thresholds to determine whether to initiate a capture sequence. As long as the incoming data remains within the specified limits, the TCM remains in *TCM\_armed* mode.

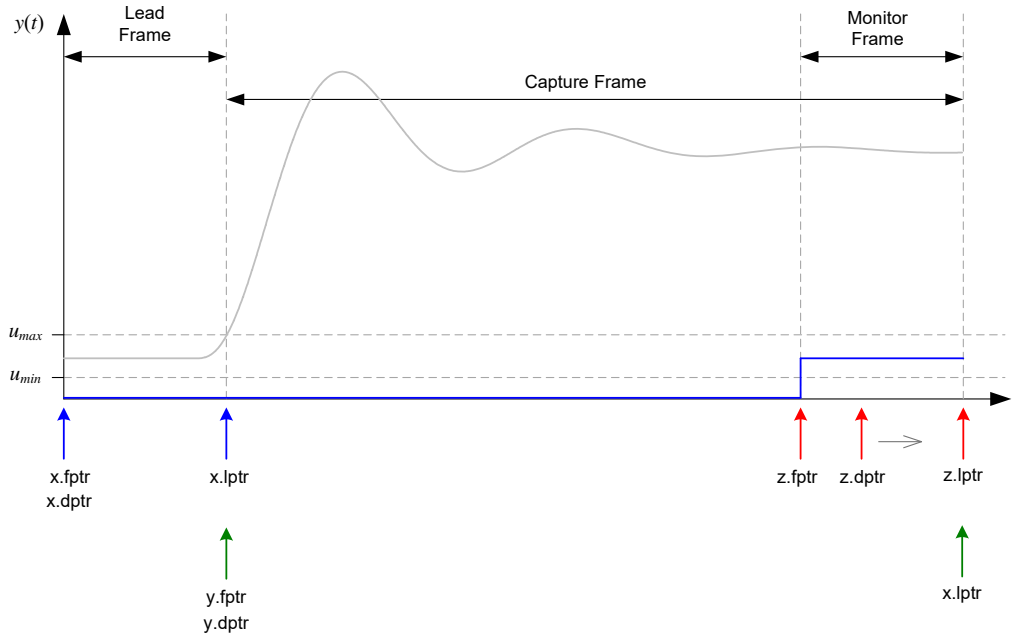

Figure 37. *TCM operation in TCM\_armed mode*

#### 4.4.3 *TCM\_capture Mode*

The first data point which exceeds either trigger threshold initiates a capture sequence. The TCM automatically enters *TCM\_capture* mode and incoming data is logged into the capture frame. Meanwhile, the monitor frame stops collecting data and starts to un-wind its contents into the lead frame. Notice that the monitor frame contains the lead data sequence, but the starting point is not aligned with the frame.

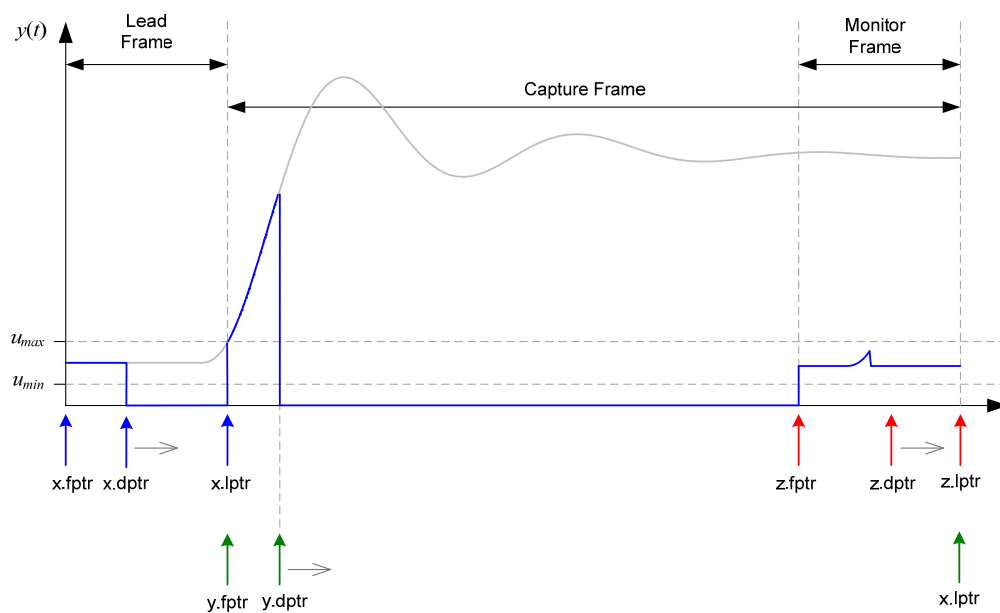

Figure 38.

### TCM operation in capture mode (monitor frame un-winding)

Once the lead frame is full, the monitor frame stops copying out its data. Incoming data continues being logged into the capture frame until it is full. The monitor frame contents have now been completely loaded into the lead frame and will be over-written.

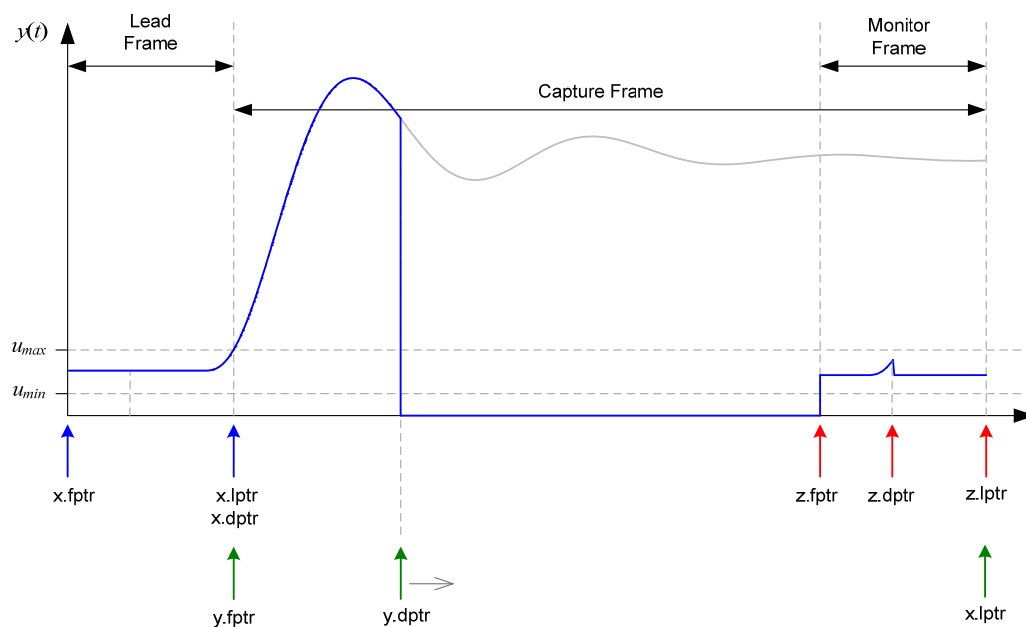

Figure 39.

### TCM operation in TCM\_capture mode (lead frame complete)

#### 4.4.4 TCM\_complete Mode

Once the capture frame is full, data logging stops and the TCM enters *TCM\_complete* mode. The capture frame pointers are adjusted to span the entire TCM buffer.

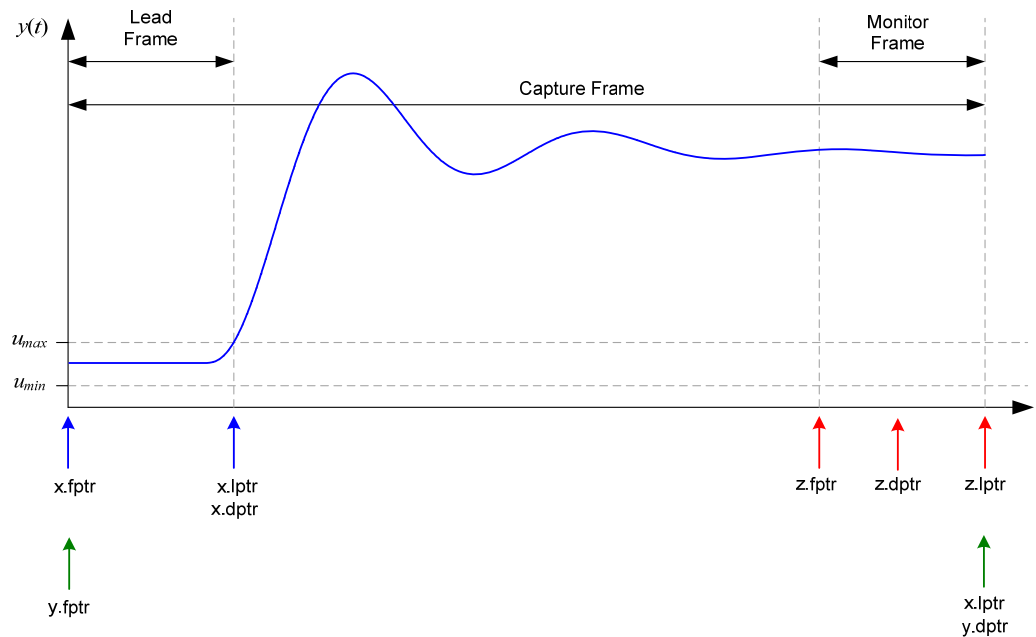

Figure 40. TCM capture complete

The buffer contents may now be read out using `DCL_readLog()` or `DCL_freadLog()`.

#### 4.4.5 Functions

##### **DCL\_initTCM**

##### **Initialize the TCM**

Header File: DCL\_TCM.h

Source File: N/A

Declaration: `void DCL_initTCM(TCM *q, float *addr, uint16_t size, uint16_t lead, float tmin, float tmax)`

Description: This function resets the TCM module. All buffer contents are loaded with zero, and the operating mode is set to "TCM\_idle".

Parameters:

q	The TCM structure
addr	The start address of the memory block
size	The size of the memory block in 32-bit words
lead	The length of the lead frame in samples
tmin	The upper trigger threshold

Return: tmax            The lower trigger threshold  
 Void

***DCL\_resetTCM******Reset the TCM***

Header File: DCL\_TCM.h  
 Source File: N/A  
 Declaration: void DCL\_resetTCM(TCM \*q)  
 Description: This function resets the TCM. The contents of the capture frame are loaded with zero. All data log pointers are re-initialized, and the operating mode is set to *TCM\_idle*.  
 Parameters: q            The TCM structure  
 Return: Void

***DCL\_armTCM******Arm the TCM***

Header File: DCL\_TCM.h  
 Source File: N/A  
 Declaration: uint16\_t DCL\_armTCM(TCM \*q)  
 Description: If the current TCM mode is *TCM\_idle*, this function changes it to *TCM\_armed*, otherwise it is unchanged.  
 Parameters: q            The TCM structure  
 Return: The current operating mode

***DCL\_runTCM******Run the TCM***

Header File: DCL\_TCM.h  
 Source File: N/A  
 Declaration: uint16\_t DCL\_runTCM(TCM \*q, float data)  
 Description: Runs the TCM module.  
 Parameters: data            The input data  
               q            The TCM structure  
 Return: The current operating mode

## 4.5 Performance Measurement

### 4.5.1 Description

The Digital Control Library includes functions for the computation of control performance. All functions are based on discrete integration over a fixed interval of a variable representing servo error. The result is a non-negative scalar representing the quality of control: the smaller the result, the better the control. The figure below shows conceptually the transient servo error during a typical transient response.

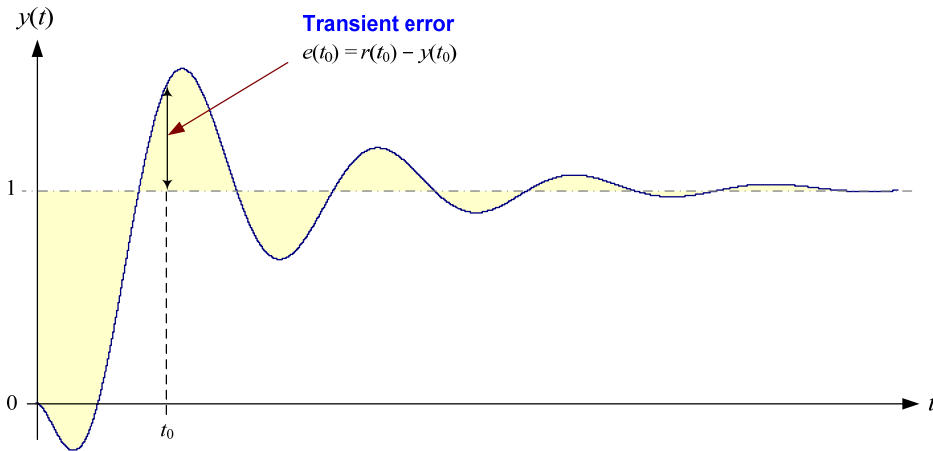

Figure 41. *Transient servo error*

There are three performance measures available in the library:

- The IES performance index is based on the square of the servo error. For an interval of  $N$  samples, with loop reference  $r$  and feedback  $y$ , the IES index ( $P_{IES}$ ) is computed as follows.

$$\text{Equation 49. } P_{IES} = \sum_{k=1}^N (r(k) - y(k))^2$$

- The IAE performance index is based on the absolute value of the servo error. For an interval of  $N$  samples, with loop reference  $r$  and feedback  $y$ , the IAE index ( $P_{IAE}$ ) is computed as follows.

$$\text{Equation 50. } P_{IAE} = \sum_{k=1}^N |r(k) - y(k)|$$

- The ITAE performance index is based on the time weighted absolute value of the servo error. For an interval of  $N$  samples, with loop reference  $r$  and feedback  $y$ , the ITAE index ( $P_{ITAE}$ ) is computed as follows.

$$\text{Equation 51. } P_{ITAE} = \sum_{k=1}^N k |r(k) - y(k)|$$

Each index is available in two forms: one coded in assembly, the other in inline C. The computation time will depend on the length of the error log, but the assembly functions will always be significantly faster.

The following table shows cycle count benchmarks for each function, for a buffer of N data points. Cycle counts include function calling overhead from C.

Table 14. Performance index function benchmarks

Function	Cycles
IES_C1	24 + 6N
IES_C2	73 + 30N
IAE_C1	24 + 6N
IAE_C2	72 + 24N
ITAE_C1	26 + 7N
ITAE_C2	77 + 31N

#### 4.5.2 Functions

##### **DCL\_runIES\_C1**

##### **Compute the IES Performance Index**

Header File:	DCL_TCM.h
Source File:	DCL_index.asm
Declaration:	float DCL_runIES_C1(FDLOG *eLog)
Description:	This function computes an IES performance index using the servo error data in a given memory block. The function is coded in assembly.
Parameters:	eLog            The servo error data log
Return:	The IES index

##### **DCL\_runIES\_C2**

##### **Compute the IES Performance Index**

Header File:	DCL_TCM.h
Source File:	N/A
Declaration:	float DCL_runIES_C2(FDLOG *eLog)
Description:	This function is equivalent to DCL_runIES_C1, but is coded in inline C.
Parameters:	eLog            The servo error data log
Return:	The IES index

**DCL\_runIAE\_C1****Compute the IAE Performance Index**

Header File: DCL\_TCM.h  
Source File: DCL\_index.asm  
Declaration: float DCL\_runIAE\_C1(FDLOG \*eLog)  
Description: This function computes an IES performance index using the servo error data in a given memory block. The function is coded in assembly.  
Parameters: eLog            The servo error data log  
Return:        The IAE index

**DCL\_runIAE\_C2****Compute the IAE Performance Index**

Header File: DCL\_TCM.h  
Source File: N/A  
Declaration: float DCL\_runIAE\_C2(FDLOG \*eLog)  
Description: This function is equivalent to DCL\_runIAE\_C1, but is coded in inline C.  
Parameters: eLog            The servo error data log  
Return:        The IAE index

**DCL\_runITAE\_C1****Compute the ITAE Performance Index**

Header File: DCL\_TCM.h  
Source File: DCL\_index.asm  
Declaration: float DCL\_runITAE\_C1(FDLOG \*eLog, float prd)  
Description: This function computes an ITAE performance index using the servo error data in a given memory block. The function is coded in assembly.  
Parameters: eLog            The servo error data log  
              prd            The sample period in seconds  
Return:        The ITAE index

**DCL\_runITAE\_C2****Compute the ITAE Performance Index**

Header File: DCL\_TCM.h  
Source File: N/A  
Declaration: float DCL\_runITAE\_C2(FDLOG \*eLog, float prd)



Description: This function is equivalent to DCL\_runITAE\_C1, but is coded in inline C.

Parameters: eLog           The servo error data log  
               prd            The sample period in seconds

Return:        The ITAE index

## 4.6 Fixed Point Data Logger Support

### 4.6.1 Description

The Digital Control Library contains support for fixed point data logging comprising a set of data buffer functions and a 4 channel data logger module. Both are similar to their floating point counterparts described earlier in this chapter. For this reason, neither will be described in detail here. The reader is referred to sections 4.2 and 4.3 for details.

### 4.6.2 Functions

#### ***DCL\_deleteLog32***

#### ***Delete a Data Log***

Header File: DCL\_log32.h

Source File: N/A

Declaration: void DCL\_deleteLog32(LOG32 \*p)

Description: This function resets all structure pointers to null value.

Parameters: p            The LOG32 structure

Return:       Void

#### ***DCL\_resetLog32***

#### ***Reset a Data Log***

Header File: DCL\_log32.h

Source File: N/A

Declaration: void DCL\_resetLog32(LOG32 \*p)

Description: This function resets the data index pointer to start of the data log.

Parameters: p            The LOG32 structure

Return:       Void

**DCL\_initLog32****Initialize a Data Log Structure**

Header File: DCL\_log32.h

Source File: N/A

Declaration: void DCL\_initLog32(LOG32 \*p, int32\_t \*addr, uint16\_t size)

Description: This function assigns the buffer pointers to a memory block or array and sets the data index pointer to the first address.

Parameters:

p	The LOG32 structure
addr	The start address of the memory block
size	The length of the memory block in 32-bit words

Return: Void

**DCL\_writeLog32****Write Data into a Log**

Header File: DCL\_log32.h

Source File: N/A

Declaration: int32\_t DCL\_writeLog32(LOG32 \*p, int32\_t data)

Description: This function writes a data point into the buffer and advances the indexing pointer, wrapping if necessary. The function returns the data value being over-written, which allows simple implementation of a fixed-length delay line.

Parameters:

p	The LOG32 structure
data	The input data value address

Return: The over-written data value

**DCL\_fillLog32****Fill a Data Log with Specified Data**

Header File: DCL\_log32.h

Source File: N/A

Declaration: void DCL\_fillLog32(LOG32 \*p, int32\_t data)

Description: This function fills the data log with a given data value and resets the data index pointer to the start of the log.

Parameters:

p	The LOG32 structure
data	The fill data value

Return: Void

**DCL\_clearLog32****Fill a Data Log Contents with Zero**

Header File: DCL\_log32.h

Source File: N/A

Declaration: void DCL\_clearLog32(LOG32 \*p)

Description: This function clears the buffer contents by writing 0 to all elements and resets the data index pointer to the start of the log.

Parameters: p                    The LOG32 structure

Return: Void

**DCL\_readLog32****Fill a Data Log Contents with Zero**

Header File: DCL\_log32.h

Source File: N/A

Declaration: int32\_t DCL\_readLog32(LOG32 \*p)

Description: This function reads a data point from the buffer and then advanced the index pointer, wrapping if necessary.

Parameters: p                    The LOG32 structure

Return: The indexed data value

**DCL\_copyLog32****Copies one Data Log into Another**

Header File: DCL\_log32.h

Source File: N/A

Declaration: void DCL\_copyLog32(LOG32 \*p, LOG32 \*q)

Description: This function copies the contents of one log into another and resets both buffer index pointers. The function assumes both logs have the same length.

Parameters: p                    The destination LOG32 structure

                  q                    The source LOG32 structure

Return: Void

**DCL\_initMLOG32****Initialize the MLOG32 Module**

Header File: DCL\_MLOG32.h

Source File: N/A

Declaration: void DCL\_initMLOG32(MLOG32 \*q, int32\_t \*addr, uint16\_t size, int32\_t tmax, int32\_t tmin, uint16\_t div)

Description: This function loads all buffer contents with zero, and resets all buffer data pointers to their respective start addresses. The upper and lower trigger thresholds, and sample time scale are loaded into the MLOG32 structure. On completion, the MLOG32 module is in *MLOG32\_idle* mode. This function is similar to `DCL_initMLOG()`. The MLOG32 module will be removed in DCL version 4.0.

Parameters:

q	The MLOG32 structure
addr	Pointer to the start address of the MLOG32 buffers
size	The size in 32-bit words of each buffer
tmax	The upper trigger threshold
tmin	The lower trigger threshold
div	The sample scaler

Return: Void

**DCL\_resetMLOG32****Reset the MLOG32 Module**

Header File: DCL\_MLOG32.h

Source File: N/A

Declaration: void DCL\_resetMLOG32(MLOG32 \*q)

Description: This function loads all buffer contents with zero, and resets all buffer data pointers to their respective start addresses. On completion, the MLOG32 module is in *MLOG32\_idle* mode. This function is similar to `DCL_resetMLOG()`. The MLOG32 module will be removed in DCL version 4.0.

Parameters:

q	The MLOG32 structure
---	----------------------

Return: Void

**DCL\_armMLOG32****Arm the MLOG32 Module**

Header File: DCL\_MLOG32.h

Source File: N/A

Declaration: void DCL\_armMLOG32(MLOG32 \*q)

Description: This function changes the MLOG32 operating mode from *MLOG32\_idle* to *MLOG32\_armed*. If the operating mode is not already *MLOG32\_idle* when the function is called, it sets the mode to *MLOG32\_idle*. This function is similar to `DCL_armMLOG()`. The MLOG32 module will be removed in DCL version 4.0.

Parameters:

q	The MLOG32 structure
---	----------------------

Return: Void

**DCL\_runMLOG32****Run the MLOG32 Module**

Header File:	DCL_MLOG32.h
Source File:	N/A
Declaration:	void DCL_runMLOG32(MLOG32 *p)
Description:	This function runs the MLOG32 module. If in the <i>MLOG32_armed</i> mode, the MLOG32 monitors its first input to determine whether either threshold has been exceeded. If so, the module enters <i>MLOG32_capture</i> mode and sample collection begins. When the buffers are full, the operating mode is set to <i>MLOG32_complete</i> . This function is similar to <code>DCL_runMLOG()</code> . The MLOG32 module will be removed in DCL version 4.0.
Parameters:	q                      The MLOG32 structure
Return:	Void

## 4.7 Simulation Models

### 4.7.1 The DCL Block-set

The Digital Controller Library is supplied with a small block-set of Simulink models prepared using Matlab release r2018b. The block-set may be found in the Simulink file `DCL.slx` in the `\models` sub-directory of the DCL installation path. The following DCL controllers are represented in the block-set.

- PID\_C1
- PID\_C3
- PI\_C1
- PI\_C3
- PI\_C5
- PI\_C7
- NLPID\_C1
- DF11\_C1
- DF13\_C1
- DF22\_C1
- DF23\_C1

It is important to understand that the blocks capture the functional structure of the controller and are intended to be used for the purposes of control loop simulation only. None of the models have been configured for automated C code generation from Simulink or Matlab. Should the user wish to do this, it is their responsibility to re-configure and build the model accordingly. Code generation currently lies outside the scope of the DCL.

## 4.7.2 Simulation Example

An example Simulink model is included with the DCL. The example files are located in the `\models` sub-directory of the DCL installation path. To see the example, open and run the script file `DCL_example.m` in Matlab.

The script will open a configuration script file `PID_config.m`, which contains the control loop settings, including the PID controller gains. These will be manually adjusted by the user each time the example is run. After the configuration is loaded into the Matlab workspace, the script then loads the input stimulus from the file `PID_inputs.m`. The user can select the type of stimulus by changing the `input_config` variable near the top of the example script file.

The example opens the Simulink model `PID_sim.slx`. The example model consists of a simple feedback control loop using a `PID_C1` controller from the DCL block-set. The plant is a third order transfer function with one LHP zero (see lines 22-30 in the configuration script file).

The simulation uses configuration parameters and input data in the Matlab workspace, and saves simulation data back to the workspace. The user may select which data to plot by setting plot variables in lines 20-25 of the example script. Plotting is performed in the script file `PID_plots.m`.

The example computes a performance index from the loop error and displays it in the Matlab command window. This is helpful should the user wish to experiment with different controller parameters to improve performance.

Any data the user wishes to save is stored in data files in the `\models` sub-directory. Each data file contains a TI header line which facilitates loading the data onto a C2000 target device.

## 4.8 Double Precision Data Logging Functions

### 4.8.1 Description

The Digital Control Library contains a double precision floating-point data logger. Apart from data type, the data logger is similar to that described in section 4.2. The data logger is supplied in the form of a C header file and may be used on any C2000 device irrespective of whether the DCL is used. The data logger is not compatible with the CLA.

The data logger operates with arrays of 64-bit floating-point data. The location, size, and indexing of each array are defined by three pointers capturing the start address, end address, and data index address. All three pointers are held in a common C structure with the data type "FDLOG64", defined as follows:

```
typedef volatile struct {
    float64_t *fptr;
    float64_t *lptr;
    float64_t *dptr;
} FDLOG64;
```

Conceptually, the relationship between the array pointers and the elements of a data array of length "N" is shown below:

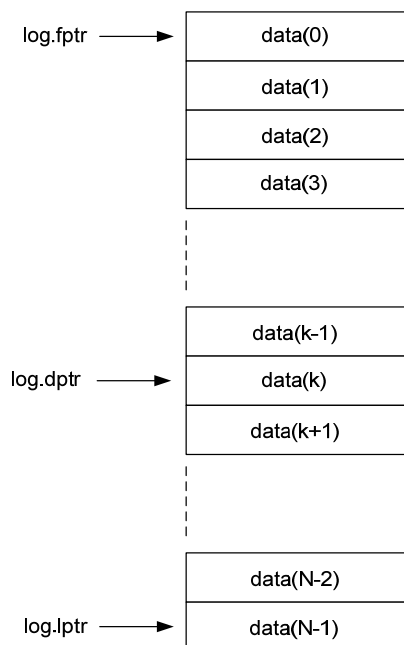

Figure 42. *FDLOG64 pointer allocation*

The data index pointer (dptr) always points to the next address to be written or read, and advances through the memory block as each new data value is written into the log. On reaching the end of the log, the pointer is reset to the first address in the log. The data logger header file contains a set of in-line C functions to access and manipulate data logs.

To use the data logger, you must include the header file `DCL_fdlog64.h` in your project. Typically, a user would create an instance of an `FDLOG64` structure as follows:

```
FDLOG64 myBuf = FDLOG64_DEFAULTS;
```

The log pointers can then be initialized in the user's code such that they reference a memory block in a specific address range. Thereafter, the code can clear or load the buffer a specific data value, and then begin writing data into it using the `DCL_writeLog64()` function.

The execution cycles for the read & write functions are shown below:

Table 15. *FDLOG64 read/write benchmarks*

DCL_writeLog64	75
DCL_readLog64	58

## 4.8.2 Functions

**DCL\_deleteLog64****Delete a Data Log**

Header File: DCL\_fdlog64.h  
 Source File: N/A  
 Declaration: void DCL\_deleteLog64(FDLOG64 \*p)  
 Description: This function resets all structure pointers to null value.  
 Parameters: p                    The FDLOG64 structure  
 Return:        Void

**DCL\_resetLog64****Reset a Data Log**

Header File: DCL\_fdlog64.h  
 Source File: N/A  
 Declaration: void DCL\_resetLog64(FDLOG64 \*p)  
 Description: This function resets the data index pointer to start of the data log.  
 Parameters: p                    The FDLOG64 structure  
 Return:        Void

**DCL\_initLog64****Initialize a Data Log Structure**

Header File: DCL\_fdlog64.h  
 Source File: N/A  
 Declaration: void DCL\_initLog64(FDLOG64 \*p, float64\_t \*addr, uint16\_t size)  
 Description: This function assigns the buffer pointers to a memory block or array and sets the data index pointer to the first address.  
 Parameters: p                    The FDLOG64 structure  
               addr                The start address of the memory block  
               size                The length of the memory block in 64-bit words  
 Return:        Void

**DCL\_writeLog64****Write Data into a Log**

Header File: DCL\_fdlog64.h



Source File: N/A

Declaration: float64\_t DCL\_writeLog64(FDLOG64 \*p, float64\_t data)

Description: This function writes a data point into the buffer and advances the indexing pointer, wrapping if necessary. The function returns the data value being over-written, which allows simple implementation of a fixed-length delay line.

Parameters: p                   The FDLOG64 structure  
               data                The input data value address

Return:           The over-written data value

**DCL\_fillLog64****Fill a Data Log with Specified Data**

Header File: DCL\_fdlog64.h

Source File: N/A

Declaration: void DCL\_fillLog64(FDLOG64 \*p, float64\_t data)

Description: This function fills the data log with a given data value and resets the data index pointer to the start of the log.

Parameters: p                   The FDLOG64 structure  
               data                The fill data value

Return:       Void

**DCL\_clearLog64****Fill a Data Log Contents with Zero**

Header File: DCL\_fdlog64.h

Source File: N/A

Declaration: void DCL\_clearLog64(FDLOG64 \*p)

Description: This function clears the buffer contents by writing 0 to all elements, and resets the data index pointer to the start of the log.

Parameters: p                   The FDLOG64 structure

Return:       Void

**DCL\_readLog64****Read Data from the Data Log**

Header File: DCL\_fdlog64.h

Source File: N/A

Declaration: float64\_t DCL\_readLog64(FDLOG64 \*p)

Description: This function reads one data point from the buffer and then advances the index pointer, wrapping to the first element if necessary.

Parameters: p                    The FDLOG64 structure

Return:                    The indexed data value

***DCL\_copyLog64***

***Copies one Data Log into Another***

Header File: DCL\_fdlog64.h

Source File: N/A

Declaration: void DCL\_copyLog64(FDLOG64 \*p, FDLOG64 \*q)

Description: This function copies the contents of one log into another and resets both buffer index pointers. The function assumes both logs have the same length.

Parameters: p                    The destination FDLOG64 structure address

                  q                    The source FDLOG64 structure address

Return:                    Void

## Chapter 5

# Examples

---

---

---

This chapter describes the example projects supplied with the Digital Control Library.

**Section**

- 5.1 Example 1: DF22 compensator running on FPU32**
- 5.2 Example 2: DF23 compensator running on CLA**
- 5.3 Example 3: NLPID controller running on FPU32**
- 5.4 Example 4: PI controller running on CLA**
- 5.5 Example 5: PID controller running on FPU32**
- 5.6 Example 6: TCM running on FPU32**
- 5.7 Example 7: Smith predictor running on FPU32**
- 5.8 Example 8: GSM running on FPU32**
- 5.9 Example 9: Multiple Controller System with ERAD running on FPU32**
- 5.10 Example 10: PID running on FPU64**
- 5.11 Example 11: NLPID Running on FPU32 (TMU1)**

The Digital Control Library package includes a set of code examples intended to illustrate the use of library functions in a typical software project. Examples are supplied as CCS projects configured for use with a specified target. Code migration to a different C2000 device is straightforward and does not affect the DCL.

There are ten example projects, located in the C2000Ware installation directory, in the sub-directory `\libraries\control\DCL\c28\examples`. Each example has a "CCS" sub-directory containing a ".projectspec" file which should be imported as a project into the users CCS workspace.

The following sections describe the example code and outline the steps to run them. The examples were prepared using CCS version 8.3.0. It is assumed the reader is familiar with CCS and how to build and run code. For further information on these topics, the reader is referred to the C2000 training workshop (section 6.2).

## 5.1 Example 1: DF22 Compensator Running on FPU32

### 5.1.1 Example Overview

This example demonstrates the DF22 compensator running on the FPU32 core. The code creates two separate instances of the DF22 compensator: one implemented using the full `DCL_DF22_C1` function, the other using the pre-computed `DCL_DF22_C2` and `DCL_DF22_C3` functions. The pre-computed compensator makes use of a clamp function to limit the compensator output.

The program contains one ISR which is triggered by a CPU timer at 1kHz. The ISR reads a single input from a data buffer and runs both DF22 compensators. The compensator outputs are compared, and then both outputs and their difference logged into three separate data buffers. When the last point of the input buffer has been read and processed, the ISR passes through the line containing a `NOF` instruction near the bottom of the program. The user can place a break-point here to examine the results of the compensator test.

The program makes use of four data buffers at the following addresses:

- `0xC000` – contains input data representing servo loop error
- `0xE000` – contains output data from the full DF22 compensator
- `0x10000` – contains output data from the pre-computed DF22 compensator
- `0x12000` – contains the difference between the two compensator outputs

Each data buffer contains 1601 single precision floating-point data points.

### 5.1.2 Code Description

The following lines in the program files `Example_F28069_DF22.c` are important:

Lines 17-34: create four data buffers and assign them to memory blocks defined in the linker file `F28069_DCL.cmd`

Lines 48-49: create instances of the two DF22 compensators

Lines 71-77: initialize the data log structures and data buffers

Lines 80-91: initialize the coefficients of the two compensators

Lines 94-95: set the clamp limits for the pre-computed compensator

Line 120: tests whether the last element in the input data buffer has been reached

Line 123: reads the input data point

Line 126: runs the full DF22 compensator

Line 129: runs the immediate part of the pre-computed compensator

Line 130 clamps the output of the pre-computed compensator

Lines 131-134: run the partial part of the pre-computed compensator

### 5.1.3 Running the Example

To run this example, first build and load the program onto the C28x device, then load the data file `DF22_edata.dat` into data memory at address `0xC000`. This file contains a pre-recorded data sequence representing simulated servo loop error at the controller input.

Place a break-point at the line indicated in the control ISR and run the program. When the program reaches the break-point, inspect the memory buffers by opening a CCS graph window. The graph setup window below shows how to configure the graph to view the pre-computed compensator output (`u2k`).

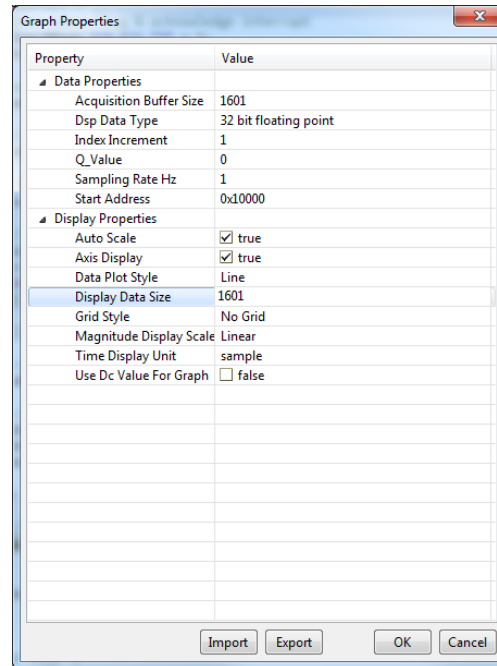

The `ek` buffer should look like this.

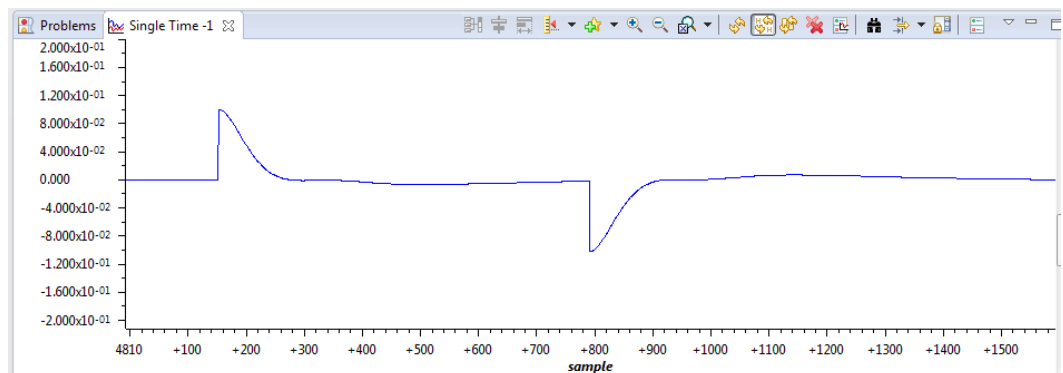

The plot of the `u1k` and `u2k` buffers should look like this.

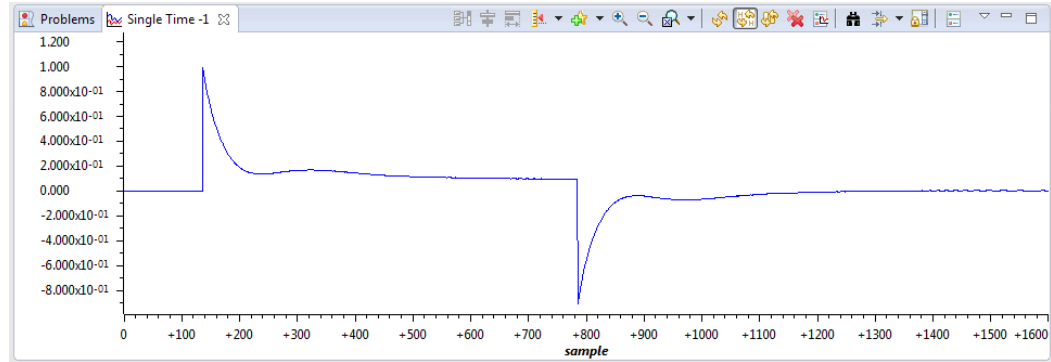

Similar graphs can be opened for the other buffers by changing the start address. The buffer at start address 0x12000 captures the difference in output between the full and pre-computed compensators, and should contain data which is zero or very small.

## 5.2 Example 2: DF23 Compensator Running on CLA

### 5.2.1 Example Overview

This example demonstrates one method of running a DF23 compensator on the CLA. In this example, incoming data is read in an ISR on the C28x CPU and passed to the CLA using a variable (*ek*) which is located in CPU-to-CLA message RAM. The ISR then triggers task 3 on the CLA and waits for it to complete.

The CLA task calls two different DF23 compensators and stores their results in two variables (*u1k* and *u2k*) which are located in CLA-to-CPU message RAM. These results are read by the CPU ISR which computes the difference between them. The ISR then stores both results and their difference to three data buffers. When the final input value has been processed in this way the ISR passes through a `NOP` instruction, allowing the user to place a break-point and inspect the results.

### 5.2.2 Code Description

The following lines in the file `Example_F28069_DF23.c` are important:

Lines 19-36: create four buffers which will be used to hold control data

Lines 42-47: create variables which will pass control data between C28x and CLA

Lines 73-79: assign data logs to the buffers and initialize them

Line 146: reads the next data point from the input data file

Line 150: triggers the CLA task which will call the DF23 compensator

Line 154: computes the difference between the two compensator results

Lines 157-159: write the compensator results into the data buffers

The following lines in the file `F28069_DF23_CLA.cla` are important:

Line 36: calls the full DF23 compensator and stores the result in u1k

Line 39: calls the immediate DF23 compensator and stores the result in u2k

Line 40: clamps the immediate result and sets the clamp flag vk

Lines 41-44: pre-compute the next partial DF23 result, providing the immediate part is in range

Lines 76-97: initialize the two DF23 compensator structures

Lines 100-101: initialize the clamp limits for the pre-computed DF23 compensator

### 5.2.3 Running the Example

To run this example, first build the project, then load the project onto the C28x and load symbols onto the CLA. Load the pre-recorded data file `DF23_edata.dat` into C28x memory at address `0xC000`. Place a break-point at the `NOP` instruction in line 164 of the file `Example_F28069_DF23.c`, and run the program.

After the break-point is reached, open a graph window to inspect the contents of the u1k memory buffer at address `0xE000`.

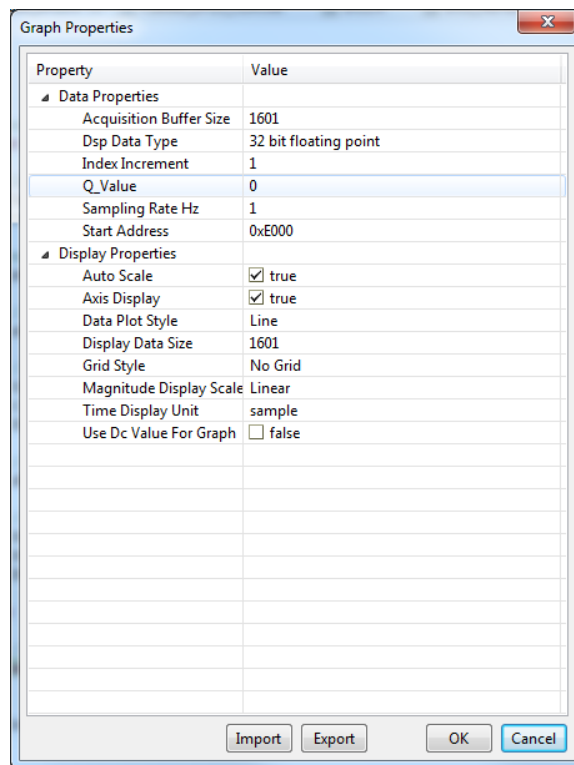

The graph contents should look like this.

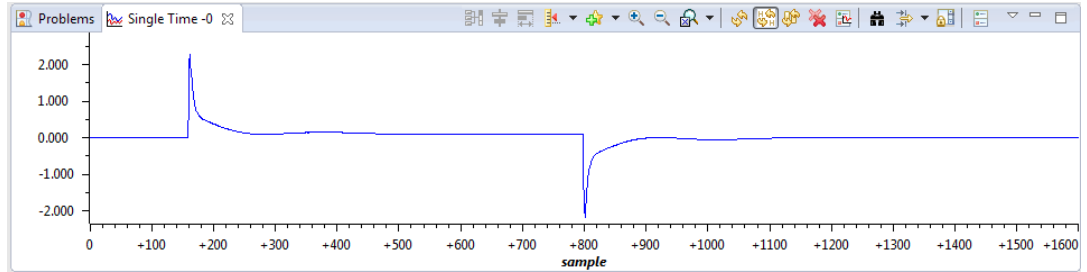

These results were produced by the full DF23 compensator. To view the pre-computed compensator, change the “Start Address” field in Graph Properties to 0x10000. The buffer at address 0x12000 contains the difference in compensator results, all of which should be zero or very small.

## 5.3 Example 3: NLPID Controller Running on FPU32

### 5.3.1 Example Overview

This example demonstrates the use of the non-linear PID controller on the FPU32 core. The code is similar to the linear PID example below except that use is made of the SPS and CSS sub-structures to update controller parameters in the background loop. Note that the program includes `DCL_NLPID.h` which contains the controller functions.

The ADC is triggered by a PWM zero match event, and samples two channels. An ISR is triggered by an ADC end-of-conversion event and reads the ADC results. Channel A0 represents the control loop feedback, and channel B0 represents an external saturation input which is used for integrator anti-windup. The `DCL_runClamp_C2` function is used to convert the ADC result into an integer with the logical value 1 or 0.

The ISR calls the `DCL_NLPID_C1` controller, and stores the control effort in the `uk` variable. This is converted into an unsigned 16-bit integer and used to modulate the PWM duty cycle. In this way, the program implements a non-linear closed loop controller which regulates the floating-point reference, `rk`.

### 5.3.2 Code Description

The following lines in the file `Example_F28069_NLPID.c` are important:

Lines 25-27: create an instance of the NLPID controller and its' sub-structures

Lines 106-107: assign the substructure addresses to the active controller structure

Lines 109-125: initialize the controller parameters in SPS shadow structure

Lines 128-120: copy the SPS parameters into the active controller structure

Line 149: updates active controller parameters if an update request is pending

Line 165: reads the control feedback and converts to signed floating-point format

Line 168: calls the non-linear PID controller function



Lines 171 – 172: set the external clamp variable to 1.0f or 0.0f.

Line 175: converts the controller output to unsigned 16-bit integer

Line 176: updates the PWM duty cycle

### 5.3.3 Running the Example

To run this example, simply build, load, and run the program on the C28x core. Place a break-point at the last instruction in the ISR (line 178) and run the program. The following variables can be monitored in a watch window:

- rk – input reference
- yk – feedback
- lk – external saturation flag
- uk – controller output
- nlpid1 – the NLPID controller structure

Expression	Type	Value	Address
(*) rk	float	0.25	0x0000B904@Data
(*) yk	float	-0.422569603	0x0000B902@Data
(*) lk	float	1.0	0x0000B90C@Data
(*) uk	float	-0.270000011	0x0000B90E@Data
▲ nlpid1	struct <unnamed>	{...}	0x0000B910@Data
(*) Kp	float	3.5	0x0000B910@Data
(*) Ki	float	0.00400000019	0x0000B912@Data
(*) Kd	float	0.349999994	0x0000B914@Data
(*) alpha_p	float	0.800000012	0x0000B916@Data
(*) alpha_i	float	0.949999988	0x0000B918@Data
(*) alpha_d	float	1.0	0x0000B91A@Data
(*) delta_p	float	0.150000006	0x0000B91C@Data
(*) delta_i	float	0.150000006	0x0000B91E@Data
(*) delta_d	float	0.150000006	0x0000B920@Data
(*) gamma_p	float	1.46144247	0x0000B922@Data
(*) gamma_i	float	1.09950054	0x0000B924@Data
(*) gamma_d	float	1.0	0x0000B926@Data
(*) c1	float	151.709396	0x0000B928@Data
(*) c2	float	0.517093956	0x0000B92A@Data
(*) d2	float	35.7122955	0x0000B92C@Data
(*) d3	float	-21.9822521	0x0000B92E@Data
(*) i7	float	0.0	0x0000B930@Data
(*) i16	float	0.0	0x0000B932@Data
(*) Umax	float	0.310000002	0x0000B934@Data
(*) Umin	float	-0.270000011	0x0000B936@Data
+ Add new expression			

The user can run repeatedly to the break-point, modifying controller parameters and examining the change of controller variables. If any of the “alpha” or “delta” parameters are changed, the variable calFlag should be set to 1 to enable the “gamma” gains to be computed and updated in the background loop.

## 5.4 Example 4: PI Controller Running on CLA

### 5.4.1 Example Overview

This example demonstrates one method of running a PI controller on the CLA. The CPU program contains an ISR which is triggered by an ADC end-of-conversion in the same way as example 3. Feedback data is read from the ADC in an ISR on the C28x CPU and passed to the CLA using a variable (*yk*) which is located in CPU-to-CLA message RAM, together with the servo reference (*rk*). The ISR converts the ADC result into signed floating-point format, then triggers task 3 on the CLA and waits for it to complete.

CLA task 3 calls the function `DCL_runPI_L1()` which computes the PI controller in an assembly function. The result is stored in the variable *uk*, which is located in CLA-to-CPU message RAM.

The PI controller result is read by the ISR, converted into a scaled un-signed 16-bit integer, and written to the PWM duty cycle register.

### 5.4.2 Code Description

The following lines in the file `Example_F28069_PI.c` are important:

Lines 24-29: create instances of the control variables and assign them to the appropriate message RAM blocks

Lines 31-32: create an instance of the PI controller structure and place it in CPU-to-CLA message RAM. This allows controller parameters to be modified from code running on the C28x CPU.

Lines 49-54: initialize the PI controller parameters

Line 170: reads the feedback data from the ADC and converts it into floating-point format

Line 177: starts CLA task 3 and waits for it to complete

Lines 180-181: convert the controller result to 16-bit unsigned integer and write it to the PWM duty cycle register

The following line in the file `F2806x_PI_CLA.cla` is important:

Line 29: calls the PI controller function `DCL_runPI_L1()`

Note that in this example, initialization of the PI controller is performed on the C28x CPU, so there is no need to allocate a separate CLA task for that purpose.

### 5.4.3 Running the Example

Build and load the project onto the C28x, then load the symbols onto the CLA. Place a break-point at the last instruction in the ISR (line 183), and run the program. Open an Expressions Window in CCS, and inspect the control variables and PI controller structure.

Expression	Type	Value	Address
(x)= rk	float	0.25	0x00001500@Data
(x)= yk	float	-0.421104044	0x00001502@Data
(x)= uk	float	3.82667089	0x00001480@Data
pi1	struct <unnamed>	{...}	0x00008C00@Data
(x)= Kp	float	5.5	0x00008C00@Data
(x)= Ki	float	0.0149999997	0x00008C02@Data
(x)= i10	float	0.135599017	0x00008C04@Data
(x)= Umax	float	10.1999998	0x00008C06@Data
(x)= Umin	float	-10.1999998	0x00008C08@Data
(x)= i6	float	1.0	0x00008C0A@Data
+ Add new expression			

At this point, controller gains can be manually changed and the code run repeatedly to observe the effect on the control variables.

## 5.5 Example 5: PID Controller Running on FPU32

### 5.5.1 Example Overview

This simple example demonstrates a common digital control scenario: a single linear PID controller running on the FPU32 core which reads an ADC channel and manipulates PWM duty cycle.

The example project contains an ISR which is triggered by an ADC end-of-conversion event. The ADC is triggered by a PWM zero match event, and samples two channels which are read by the ISR. Channel A0 represents the control loop feedback, and channel B0 represents an external saturation input which is used for integrator anti-windup. The `DCL_runClamp_C1` function is used to convert the ADC result into an integer with the logical value 1 or zero.

The ISR calls the `DCL_PID_C4` parallel form PID controller to compute control effort held in the “uk” variable. This is converted into an unsigned 16-bit integer and used to modulate the PWM duty cycle. In this way, the program implements a simple closed loop PWM controller which regulates the floating-point reference, “rk”.

### 5.5.2 Code Description

The following lines in the example file `Example_F28069_PID.c` are important:

Lines 102-113: initialize the elements of the PID structure

Line 115: sets the reference input to the control loop

Line 116: initializes the external saturation flag

Line 145: reads the feedback and converts to the range  $\pm 1.0f$

Line 148: runs the PID controller

Lines 151-152: set the external clamp variable  $1.0f$  or  $0.0f$

Line 155: convert the controller output to unsigned integer in the range 0 to PRD

Line 156: writes the result to PWM duty cycle register

### 5.5.3 Running the Example

To run this example, simply build, load, and run the program on the C28x core. Place a break-point at the last instruction in the ISR (line 158) and run the program. The following variables can be monitored in a watch window:

- rk – input reference
- yk – feedback
- lk – external saturation flag
- uk – controller output
- pid1 – the PID controller structure

Expression	Type	Value	Address
(x)= rk	float	-0.41475001	0x0000B900@Data
(x)= yk	float	-0.415241808	0x0000B902@Data
(x)= lk	float	1.0	0x0000B90A@Data
(x)= uk	float	0.157283574	0x0000B90C@Data
pid1	struct <unnamed>	{...}	0x0000B90E@Data
(x)= Kp	float	1.0	0x0000B90E@Data
(x)= Ki	float	0.000149999993	0x0000B910@Data
(x)= Kd	float	0.349999994	0x0000B912@Data
(x)= Kr	float	1.0	0x0000B914@Data
(x)= c1	float	188.029663	0x0000B916@Data
(x)= c2	float	0.880296588	0x0000B918@Data
(x)= d2	float	0.0323654078	0x0000B91A@Data
(x)= d3	float	0.116397053	0x0000B91C@Data
(x)= i10	float	0.0245669596	0x0000B91E@Data
(x)= i14	float	1.0	0x0000B920@Data
(x)= Umax	float	1.0	0x0000B922@Data
(x)= Umin	float	-1.0	0x0000B924@Data
+ Add new expression			

The user can run repeatedly to the break-point modifying controller parameters and examining the change of controller variables.

## 5.6 Example 6: TCM Running on FPU32

### 5.6.1 Example Overview

This example illustrates the use of the TCM to capture a portion of a pre-recorded sample transient response. The code demonstrates how to configure and use the TCM, together with computation and storage of servo error, use of the fast read & write data log functions, and use of the performance index functions.

The code contains a single ISR triggered at 1kHz by a CPU timer. The ISR uses the fast read function `DCL_fread()` to read values from two buffers representing servo reference (rBuf), and feedback (yBuf), and then runs the TCM on the feedback sample to detect and

capture the transient response in a third buffer (dBuf). The code subtracts  $y_k$  from  $r_k$  to find the instantaneous servo error, and logs the result into a fourth buffer (eBuf). When the final point in the input data sequence has been read and acted upon, the dBuf buffer should contain a portion of the feedback sequence around the transient edge, while the eBuf buffer contains the servo error. The variables P1, P2, and P3 contain the ITAE, IAE, and IES performance indices respectively. These are computed over the entire input sequence.

### 5.6.2 Code Description

The following lines in the file `Example_F28069_TCM.c` are important:

Lines 20-37: create instances of four data buffers and assign them to specific regions defined in the linker command file `F28069_DCL.cmd`.

Lines 44-46: create instances of the control variables

Line 47: creates an instance of the TCM module and initializes it to default values

Lines 48-50: create variables to hold the performance indices

Lines 72-76: assign the data buffers to FDLOG structures and clear the servo error buffer

Lines 106-107: read the servo reference and feedback data

Line 110: runs the TCM

Lines 113-114: compute the servo error and log it to the eBuf data buffer

Line 117: detects if the final point in the input buffer has been processed

Lines 123-125: compute the three performance indices

### 5.6.3 Running the Example

To run this program, build and load the project onto the target device. Then, load the two supplied data files `TCM_input.dat` and "TCM\_response.dat" into data memory addresses `0xc000` and `0xe000` respectively. Place a break-point on the `NOP` instruction at the bottom of the ISR, and run the program.

When the break-point is reached, open a graph window to view the contents of the 1601-point `yBuf` memory at address `0xe000`.

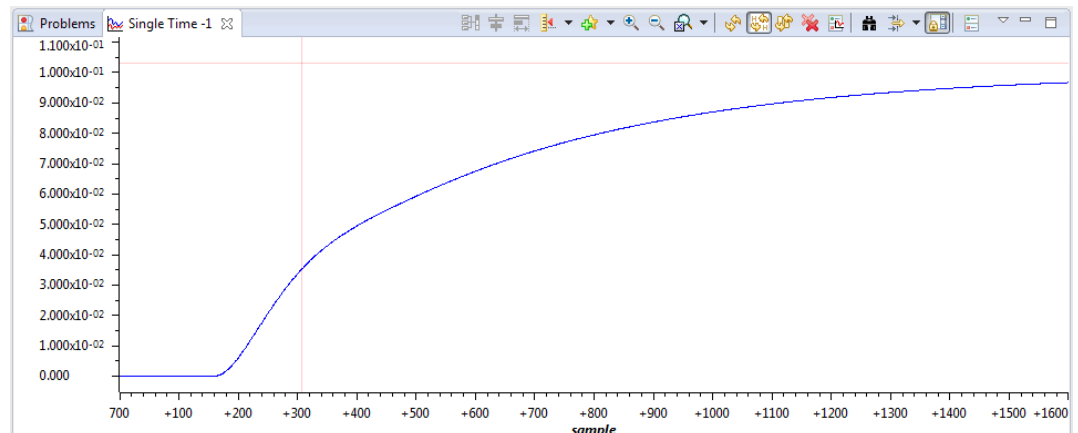

Open a second graph to display the 350-point contents of the dBuf buffer at address 0x12000.

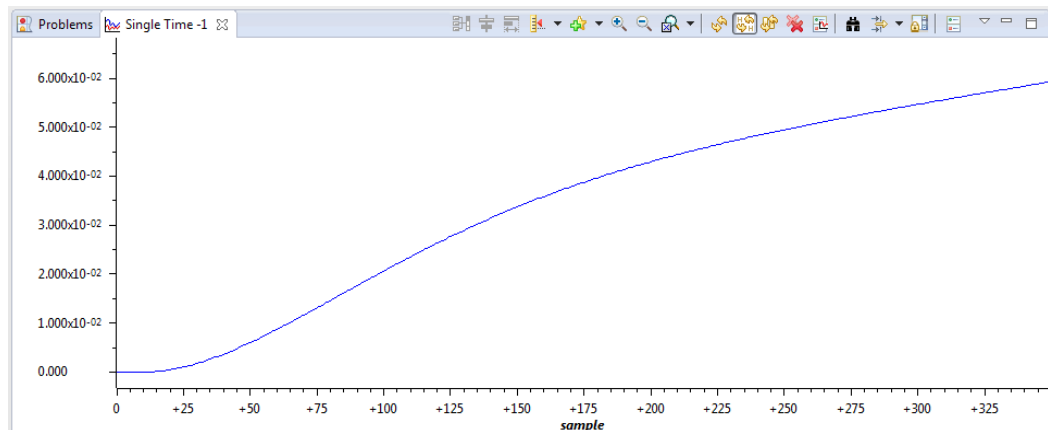

The TCM buffer contains part of the feedback data near the transient. Notice that the first part of the TCM buffer (approximately 25 samples) contains data which has not exceeded either trigger threshold. This is the lead frame.

## 5.7 Example 7: Smith Predictor Running on FPU32

### 5.7.1 Example Overview

This example illustrates the simultaneous use of two direct form compensators, together with a time delay implemented using a data logger to construct a Smith predictor. The Smith predictor facilitates control of systems which incorporate a fixed time delay. To construct the controller, the plant and the time delay must be known since the controller includes models of both. The architecture of the basic Smith predictor is shown below.

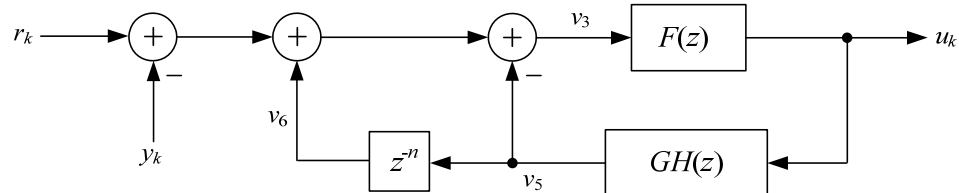

Figure 43.

Smith Predictor control loop

In this example, the plant has a third order characteristic and the delay line is 13 sample periods in duration. The plant transfer function  $GH(z)$  is shown in the source code. The controller  $F(z)$  is also third order, implemented using a DF23 structure.

### 5.7.2 Code Description

The following lines in the file `Example_F28069_Smith.c` are important:

Lines 25-28: create an instance of the DF23 controller and sub-structures (note that the sub-structures are not used in this example).

Lines 34-37: create the delay line which we will use to model time delay in the plant

Lines 102-103: initialize the delay line and buffer pointers

Lines 110-117: initialize the plant model

Lines 120-126: initialize the controller

Lines 158-161: execute the controller

### 5.7.3 Running the Example

To run this program, build and load the project onto the target device. Then, set a break-point on line 155 and run the code. At this point the user may step through the example code and verify the controller and delay line are working as expected. For example, the variable `v3` could be added to the CCS Expressions window and monitored as the program is run between break-points.

To verify the working of the delay model, add the variable `v6` and the delay line array "p\_array" to the expressions window, then set a break-point at the end of the ISR and observe the data updates in the array.

## 5.8 Example 8: GSM Running on FPU32

### 5.8.1 Example Overview

This example illustrates the setup and use of the Gain Scheduler Module running on an F28069. The code makes no use of the device peripherals.

The example is configured to construct a  $y = x^2$  target profile. Offsets and gains are loaded into the SPS, and the update performed using the `DCL_updateGSM()` function.

### 5.8.2 Code Description

The following lines in the file `Example_F28069_GSM.c` are important:

Lines 23-25: create instances of the GSM module and supporting sub-structures, initialized with their default values.

Lines 41-42: Initialize the results buffer which will hold the input-output curve.

Lines 45-46: load the GSM sub-structure addresses.

Lines 49-54: load the GSM shadow offset table from a target function.

Line 57: loads the shadow gain table from the shadow offsets.

Lines 60-61: copy the shadow parameter sets into the active controller tables.

Lines 64-69: run the GSM to construct the input-output table and store it in the results buffer.

Lines 80-84: contain the target profile function.

### 5.8.3 Running the Example

To run this program, build and load the project onto the target device. Then, set a break-point at the NOP instruction in the while loop at line 74.

Open a graph window to view the contents of the result buffer. The graph properties window should be configured as follows.

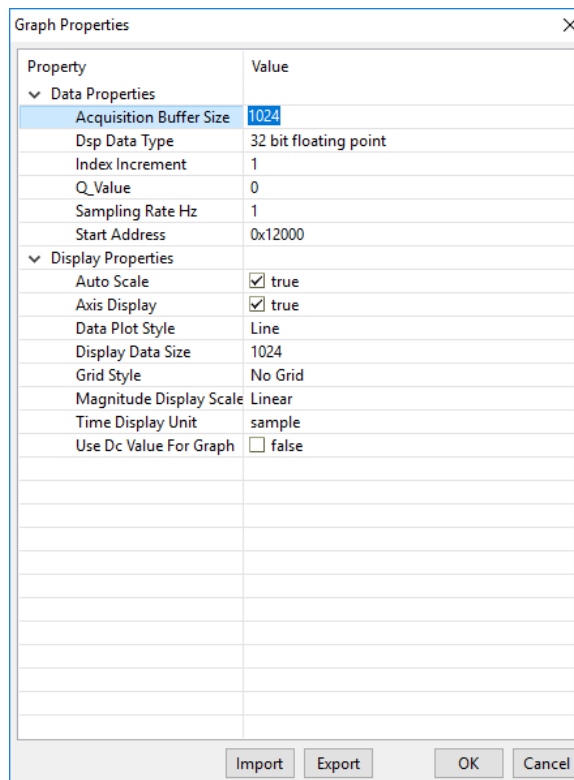

The graph shows the GSM input-output curve and for the default target function ( $y = x^2$ ) should look like this:



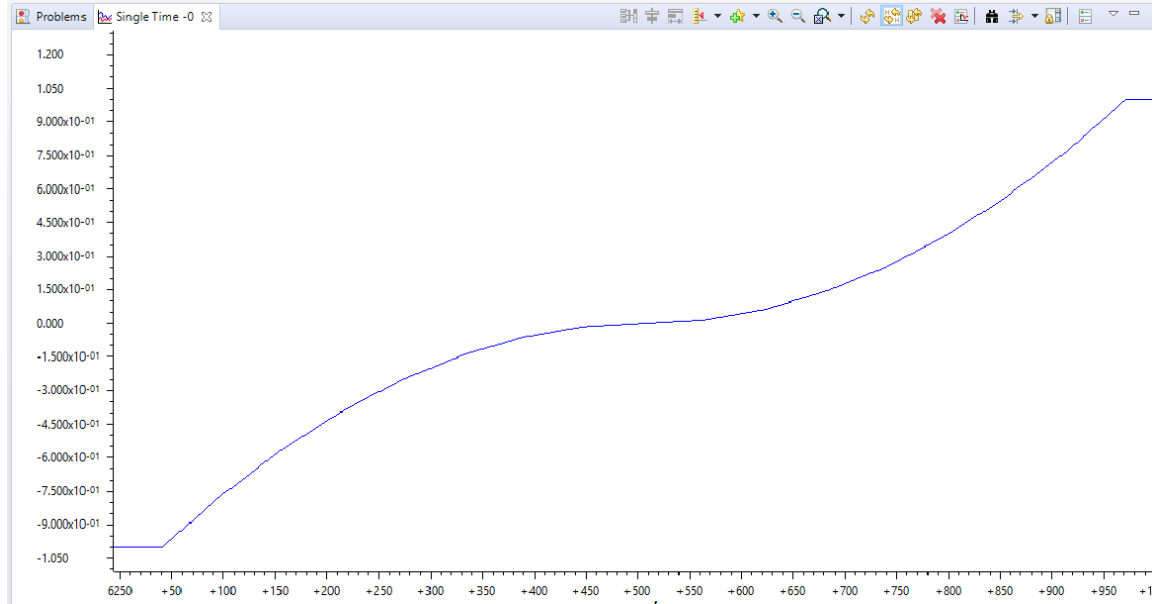

The user is invited to experiment with different target functions.

## 5.9 Example 9: Multiple Controller System with ERAD Running on FPU32

### 5.9.1 Example Overview

This example illustrates the simultaneous use of multiple DCL controllers running at different update rates on an F28049. This device contains debug hardware known as Embedded Real-time Analysis and Diagnostics (ERAD) which is capable of profiling the system without having to connect an emulator. Among other things, the ERAD can measure the execution time of a specified code function. The example demonstrates use of ERAD to determine CPU bandwidth in a complex control application consisting of three separate control interrupts, as follows.

ISR	Rate (kHz)	CPU Timer
a	10	1
b	253	2
c	60	3

ISR (a) reflects a situation common in field oriented motor control in which a relatively low rate PID controller, possibly regulating shaft speed, is cascaded with two parallel PI

current control loops running approximately ten times faster. The interrupt runs at 10 kHz, and the PID controller is “time sliced” to run ten times slower, at 1 kHz.

ISR (b) represents a higher rate loop, perhaps regulating other power electronics sub-systems such as PFC control. The ISR contains a gain scheduler and DF11 compensator in cascade, running at the full 253 kHz rate. Also in this ISR is a DF22 compensator which is “time sliced” to run at one third of the interrupt rate.

The last loop, ISR (c), contains a DF23 compensator and is configured with a varying payload, so that the execution time changes as the program runs. Also, the DF23 compensator coefficients are updated periodically in the background loop.

The overall program is fairly demanding from the point of view of computational load and the programmer might reasonably wish to know the CPU bandwidth to ensure hard real-time deadlines are being met. This information can be found using the hardware ERAD module. Refer to the ERAD chapter in the TMS320F28004x Technical Reference Manual for information on the ERAD module and registers.

This example uses the ERAD module to measure the CPU “bandwidth”: the amount of cycles available after all the application real-time requirements have been met. To determine this, we measure the number of CPU cycles between consecutive calls to the slowest interrupt in the system, and subtract from it the total number of cycles spent servicing interrupts over the same interval. This is equivalent to the number of cycles spent in the background loop over the longest interrupt interval and is usually expressed as a percentage.

In this example, we could have 3 or 4 ISR (b) calls and 5 or 6 ISR (c) calls between two consecutive ISR (a) calls.

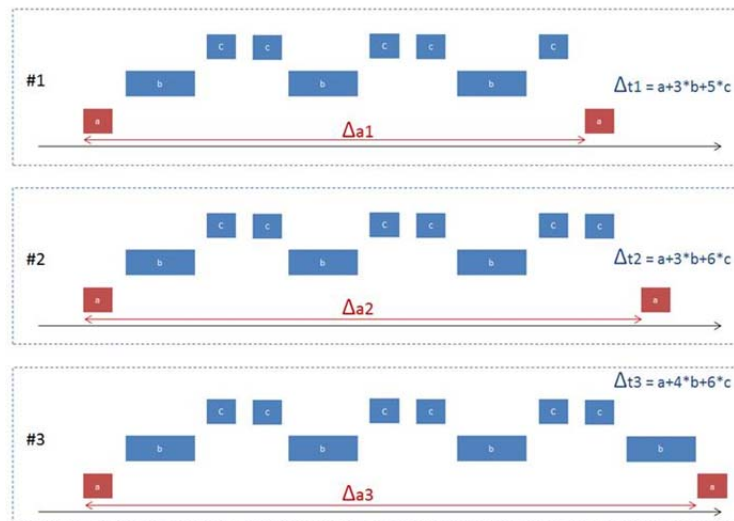

With reference to the above figure, the example code measures the worst case CPU availability as follows:

```
MaxWindowCycles = Max(Δa1, Δa2, Δa3);
MaxISRCycles    = Max(Δt1, Δt2, Δt3);
```

Then we compute available CPU bandwidth in % using

$$\text{CPU bandwidth} = 100 \times (\text{MaxWindowCycles} - \text{MaxISRCycles}) / \text{MaxWindowCycles}$$

### 5.9.2 Code Description

The example code makes use of an API function set to configure the ERAD module.

The example links all the ISR code to a single named section (“interruptSection”) for ease of profiling. Refer to the files `F280049_ERAD.cmd` and `F280049_stdmem.cmd` to see how this is done. Note that the method of configuring the ERAD module involves the use of API functions contained in the source file `f28004x_dcl_erad.c`.

The following lines in the file `Example_F280049_ERAD.c` are important.

Lines 8 – 39: create instances of the controllers and control variables used in the program, and define the constants used for decimation.

Lines 79 – 148: initialize the controller parameters.

Lines 168 – 169: update the DF23 controller parameters used in ISR (c).

Lines 174 – 187: tests the number of passes through the background loop and halts execution when the number exceeds (arbitrarily) 1000, after which CPU timers are stopped and the PC is trapped in an infinite “while” loop.

Lines 192 – 244: contain the three interrupt service routines, each of which is associated with the named section “interruptSection” using a `CODE_SECTION` pragma.

Lines 247 – 315: configure the ERAD registers using the API set to capture the information described in the previous section.

### 5.9.3 Running the Example

To run this program, build and load the project onto the target device. Then, place a break-point on line 186 of the file `Example_F280049_ERAD.c`.

Open an Expressions window in CCS and add the variables shown below, then run the program. The values should be similar to those shown below.

Expression	Type	Value
IsraCount	unsigned int	121
IsrbCount	unsigned int	1772
IsrcCount	unsigned int	469
IdleLoopCount	unsigned long	1000
MaxISRCycles	unsigned long	12136
MaxWindowCycles	unsigned long	19240

The best case CPU bandwidth measured over 1000 cycles is:

$$100 \times (19240 - 12136) / 19240 = 36.92\%$$

The user may like to experiment with the configuration of the ERAD module to make other measurements.

## 5.10 Example 10: PID Running on FPU64

### 5.10.1 Example Overview

This example demonstrates a double precision PID controller running on an F28388D device. The code makes use of the FPU64 accelerator on this device and is built for EABI.

The example comprises a single C source file, `Example_F28388D_PIDF64.c`. This file has a `main()` function which initializes the device and controller, an ISR triggered by CPU timer 0 which executes the controller, and a timer initialization routine.

To simulate a control loop, the user will load example set-point data (`rk`) and feedback data (`yk`) into two pre-defined buffers in internal RAM. These, together with integrator clamp data (`lk`) are processed sequentially by the controller and the results (`uk`) stored in a separate buffer. The buffer names and addresses are as follows:

Data	Struct	RAM block	Start address
<code>rk</code>	<code>pBuf</code>	GS12	0x19000
<code>yk</code>	<code>qBuf</code>	GS13	0x1A000
<code>lk</code>	<code>rBuf</code>	GS14	0x1B000
<code>uk</code>	<code>sBuf</code>	GS15	0x1C000

### 5.10.2 Code Description

The following lines in the file `Example_F28388D_PIDF64.c` are important:

Lines 15-18: use the `DATA_SECTION` pragma to associate array names with sections in the linker command file `F28388D_DCL.cmd`.

Lines 21-24: associate names with the start addresses of these sections.

Lines 27-30: create instances of the four data buffers used in the test.

Lines 33-36: create instances of the data log structures which will manage the buffers.

Line 45: creates an instance of the PIDF64 controller and initializes it with default data. Open and inspect the header file `DCLF64.h` to see these definitions.

Lines 69-74: initialize the data buffers. Notice that the “`rBuf`” buffer, which contains the `lk` data, is initialized to hold all 1’s. This is because in this test the loop does not saturate. The variable “`lk`” is used by the controller to implement integrator anti-windup from an external point in the loop, so we need this input to always be 1.

Lines 109-111: read the input data from the three input buffers. Typically this data would come from an ADC, but in this test we are reading pre-recorded data.

Line 114: calls the controller function.

Line 117: stores the output of the controller.

### 5.10.3 Running the Example

To run this example, first build and load the project onto the target F28388D device in the normal way.

Then, set break-points at the two DCL\_BREAK\_POINT instructions in lines 86 and 97.

Run the program so that the PC stops at the first break-point.

Load the r(k) and y(k) data into the device as follows:

- Open a memory browser to view address 0x19000.
- Set the data type to 64-bit Floating Point.
- Load the data file “rdata.dat” at this address. Set the data length to 1024.
- Load the data file “ydata.dat” to address 0x1A000 with similar length.
- In the memory browser, view the controller output buffer at address 0x1C000.

Run the program so that it reaches the second break-point. The controller has now processed all the points in the input buffers and the results are stored in RAMGS15.

Open a graph window to view the contents of the result buffer at address 0x1C000. The graph properties should look like this:

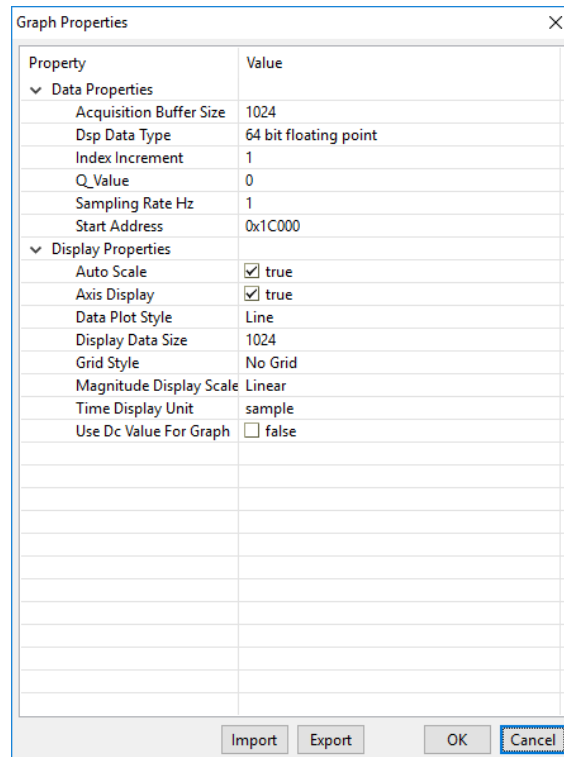

The display should look like this:

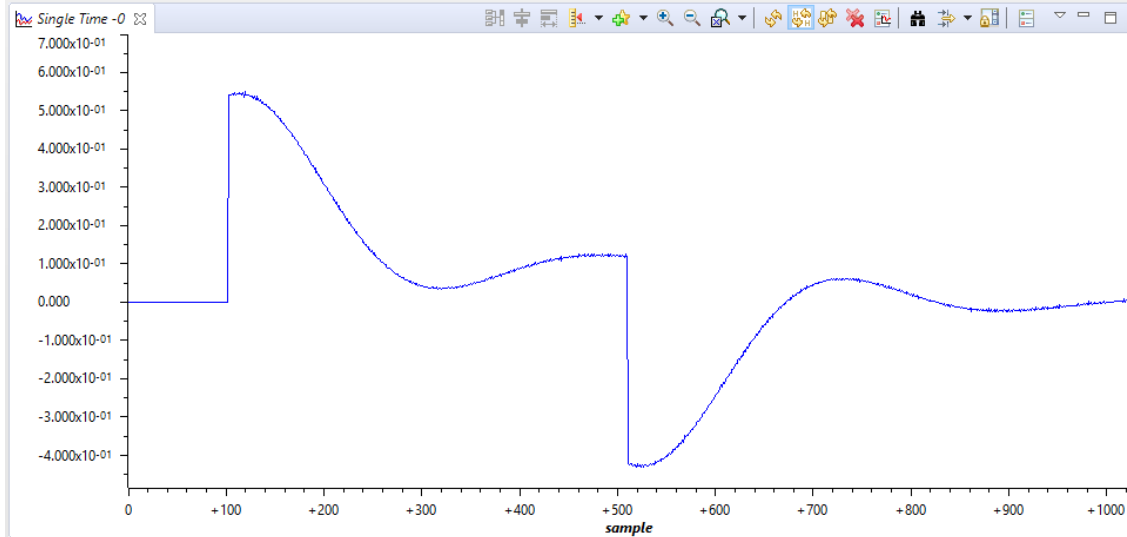

## 5.11 Example 11: NLPID Running on FPU32 (TMU1)

### 5.11.1 Example Overview

This example demonstrates a nonlinear PID controller running on an F280025 device. The controller is coded in assembly and requires the type 1 TMU to implement the power function which is used in the nonlinear control law. Refer to section 3.3 for more information on this controller.

The example is supplied with the following data files:

NLPID_input.dat	an input reference waveform representing a step function
NLPID_feedback.dat	a waveform representing control loop feedback in response to the above test function
NLPID_control.dat	the expected controller output
NLPID_testdata.dat	the actual controller output generated in the test

### 5.11.2 Code Description

A detailed code example is omitted for this example. Refer to the comments in the source files for further information.

### 5.11.3 Running the Example

Open the example using the .projectspec file in the \CCS sub-directory of the example folder. Then build and load the project onto the target F280025 device in the normal way.

Open a memory browser window and configure it to view 32-bit floating point data beginning at address 0xB800 in data space. Right-click in the memory window and load the data file NLPID\_input.dat at this address. Set the data length to 501.

Load the data file NLPID\_feedback.dat to memory address 0xBC00 in a similar way.

View the memory at address 0xC000 in the memory browser. Then, in the source file `Example_F280025_NLPID.c`, set a break-point on the `DCL_BREAK_POINT` instruction in the while loop at the end of the main program.

Run the program. After a short delay, the PC should stop at the break-point and the memory browser window be updated with the test data (you may have to scroll down in the memory browser to see the new data).

Save the test data by right-clicking in the memory browser window and selecting “Save Memory...”. Enter the filename “`NLPID_testdata.dat`” in the example directory, and save 501 words of 32-bit floating point data starting at address 0xC000.

The test results data file can be imported into Matlab for comparison with the expected data. The waveform should look similar to that below.

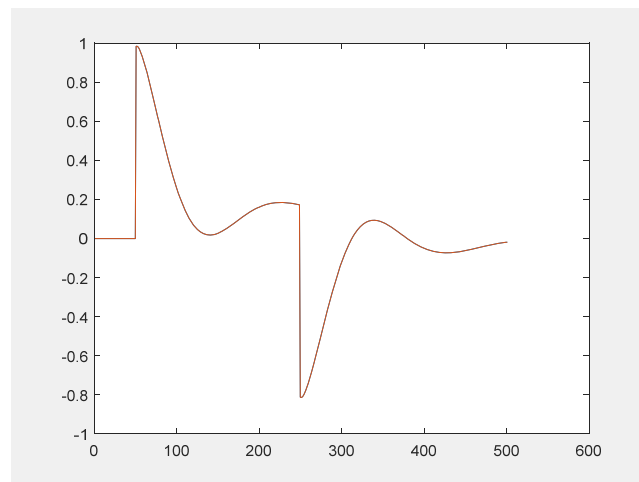

# Support

---

---

---

This chapter contains a list of useful technical resources relevant to the DCL.

## Section

6.1 References

6.2 Training

6.3 Support

## 6.1 References

### 6.1.1 C2000 Documentation

Documentation for C2000 MCU devices can be found on their respective product pages at [www.ti.com/c2000](http://www.ti.com/c2000). The following references are relevant to the DCL.

- *TMS320C28x Assembly Language Tools User's Guide*  
<http://www.ti.com/lit/ug/spru513m/spru513m.pdf>
- *TMS320C28x Optimizing C/C++ Compiler User's Guide*  
<http://www.ti.com/lit/ug/spru514m/spru514m.pdf>
- *TMS320C28x CPU & Instruction Set User's Guide*  
<http://www.ti.com/lit/ug/spru430f/spru430f.pdf>
- *TMS320C28x Floating Point Unit & Instruction Set Reference Guide*  
<http://www.ti.com/lit/ug/sprueo2b/sprueo2b.pdf>
- *TMS320x2803x Piccolo Control Law Accelerator (CLA) Reference Guide*  
<http://www.ti.com/lit/ug/spruge6b/spruge6b.pdf>

### 6.1.2 Literature

The following is a selection of publications on control theory.

- *Feedback & Control Systems*  
J.J.DiStefano, A.R.Stubberud & I.J.Williams, Schaum, McGraw-Hill, 2011
- *Digital Control of Dynamic Systems*  
G.F.Franklin, J.D.Powell & M.L.Workman, Addison-Wesley, 1998



- *Control Theory Fundamentals*  
R.Poley, CreateSpace, 2015

## 6.2 Training

- Training materials for the C2000 devices from Texas Instruments can be found at [training.ti.com/c2000-workshops](http://training.ti.com/c2000-workshops)
- Information about a series of technical seminars in control theory, including video recordings, can be found at <https://sites.google.com/site/controltheoryseminars/>

## 6.3 Support

Technical support on the DCL is available via the C2000 e2e forum, at [e2e.ti.com/support/microcontrollers/c2000](http://e2e.ti.com/support/microcontrollers/c2000)

Reports of errors or omissions, or suggestions for additions and improvements to the library, are always welcome via the e2e forum.

## IMPORTANT NOTICE AND DISCLAIMER

TI PROVIDES TECHNICAL AND RELIABILITY DATA (INCLUDING DATASHEETS), DESIGN RESOURCES (INCLUDING REFERENCE DESIGNS), APPLICATION OR OTHER DESIGN ADVICE, WEB TOOLS, SAFETY INFORMATION, AND OTHER RESOURCES "AS IS" AND WITH ALL FAULTS, AND DISCLAIMS ALL WARRANTIES, EXPRESS AND IMPLIED, INCLUDING WITHOUT LIMITATION ANY IMPLIED WARRANTIES OF MERCHANTABILITY, FITNESS FOR A PARTICULAR PURPOSE OR NON-INFRINGEMENT OF THIRD PARTY INTELLECTUAL PROPERTY RIGHTS.

These resources are intended for skilled developers designing with TI products. You are solely responsible for (1) selecting the appropriate TI products for your application, (2) designing, validating and testing your application, and (3) ensuring your application meets applicable standards, and any other safety, security, or other requirements. These resources are subject to change without notice. TI grants you permission to use these resources only for development of an application that uses the TI products described in the resource. Other reproduction and display of these resources is prohibited. No license is granted to any other TI intellectual property right or to any third party intellectual property right. TI disclaims responsibility for, and you will fully indemnify TI and its representatives against, any claims, damages, costs, losses, and liabilities arising out of your use of these resources.

TI's products are provided subject to TI's Terms of Sale ([www.ti.com/legal/termsofsale.html](http://www.ti.com/legal/termsofsale.html)) or other applicable terms available either on [ti.com](http://ti.com) or provided in conjunction with such TI products. TI's provision of these resources does not expand or otherwise alter TI's applicable warranties or warranty disclaimers for TI products.

Mailing Address: Texas Instruments, Post Office Box 655303, Dallas, Texas 75265  
Copyright © 2019, Texas Instruments Incorporated